

LAB MANUAL

ON

BASIC MECHANICAL ENGINEERING LAB

For

4TH SEM DRILLING ENGG

(SCTE&VT SYLLABUS)

Prepared by

Er Barun Kumar Barik

Lecturer Mechanical Engg

OSME KEONJHAR

Contents

1. Vision Mission of the Institute
2. Vision Mission of the Department
3. PEOs
4. POs
5. COs
6. Laboratory Regulations and Safety Rules
7. Index
8. Experiment
9. DOS and DON'T S

SAMPLE

VISION OF THE INSTITUTE:

1. To contribute to India and the world through excellence in scientific and technical education, to serve as a valuable resource to industry and society and to remain a source of pride for all Indians.
- 2.

MISSION OF THE INSTITUTE:

3. M1: Imparting total quality education to develop innovative, entrepreneurship and ethical future professionals fit for globally competitive environment.
4. M2: To provide valuable resources for industry and society through excellence in technical education.
5. M3: To develop human potential to its fullest extent so that intellectually capable and imaginatively gifted leaders can emerge in a range of profession.

VISION OF THE DEPARTMENT:

To produce quality drilling engineers, those can be valuable resources for the nation as well as for the world on problem solving and technological development.

MISSION OF THE DEPARTMENT:

1. To develop state of art facilities for classroom and laboratory related to Drilling engineering which fortify students with strong fundamental concepts, analytical capability, and problem solving skills.
2. To collaborate with different national and international organisations in same dimension which promote learning beyond curriculum and skill of new technology.
3. To develop human potential to meet industrial and societal requirement.

	Course Outcomes and Program Outcomes	
--	---	--

Semester-4th Semester Subject-Basic Mechanical Engg. Lab & Sub Code: Pr.3

Course	Statement
C215.1	Summarise UTM, stress-strain curve for ductile material, construction and working principle of governor.
C215.2	Examine compressive strength of various materials.
C215.3	Calculate hardness, bending stress and impact strength of different material.
C215.4	Calculate Mechanical advantage, Velocity ratio and efficiency of screw jack.
C215.5	Prepare various jobs by using lathe, shaping, drilling and milling machines.

3.1.2. CO-PO matrices of courses**Semester-4th Semester Subject-Basic Mechanical Engg. Lab & Sub Code: Pr.3**

Course Outcome	PO1	PO2	PO3	PO4	PO5	PO6	PO7
C215.1	3	3	3	3	2	1	3
C215.2	3	3	3	3	2	1	3
C215.3	3	3	3	3	2	1	3
C215.4	3	3	3	3	2	1	3
C215.5	3	3	3	3	2	1	3
C215 TOTAL	15	15	15	15	10	5	15
Correlation Level	3	3	3	3	2	1	3

A) PO:

1. Basic and Discipline specific knowledge: Apply knowledge of basic mathematics, science and engineering fundamentals and engineering specialization to solve the engineering problems.
2. Problem analysis: Identify and analyze well-defined engineering problems using codified standard methods.
3. Design/ development of solutions: Design solutions for well-defined technical problems and assist with the design of systems components or processes to meet specified needs.
4. Engineering Tools, Experimentation and Testing: Apply modern engineering tools and appropriate technique to conduct standard tests and measurements.
5. Engineering practices for society, sustainability and environment: Apply appropriate technology in context of society, sustainability, environment and ethical practices.
6. Project Management: Use engineering management principles individually, as a team member or a leader to manage projects and effectively communicate about well-defined engineering activities.
7. Life-long learning: Ability to analyze individual needs and engage in updating in the context of technological changes. (

B) PROGRAM SPECIFIC OUTCOME (PSOs)

PSO1: Study about Geology, Surveying Method and different Drilling methods according to application, Machineries associated with it and Terminology used in drilling,

PSO2: Selection of appropriate tools and drilling methods, keeping in view of Core recovery, Exploration of Mineral, Hydrocarbon, Ground water, Geothermal energy.

PSO3: Analyse the problems associated with geological formation, core recovery, drilling tools, drilling procedure and well conditioning during drilling operation and find out the solution to it and design a bore hole.

PSO4: Able to manage drilling projects, Become an entrepreneur in drilling field and practice sustainable development

Course Outcome	PSO1	PSO2	PSO3	PSO4
C215.1	3	2	2	2
C215.2	3	2	2	2
C215.3	3	2	2	2
C215.4	3	2	2	2
C215.5	3	2	2	2
C 215 TOTAL	15	10	10	10
Correlation Level	3	2	2	2

1: LOW 2: MEDIUM 3: HIGH

SIGNATURE OF THE TEACHER

Laboratory Regulations and Safety Rules

1. Read the instructions mentioned in the manual carefully and then proceed for the experiment.
2. Mishandling of lab equipment will not be tolerated at all. If any student is found guilty; he/she should be punished/ discarded from the lab.
3. Care must be taken while dealing with electrical connections.
4. Issued the needed/ supporting equipments by the concerned teacher/lab technician & return the same duly before leaving the lab.
5. If any defect or discrepancy noticed in the particular instrument/equipment while the students are using, they will be fined/ punished for the same.
6. Put your bags on the rack outside the lab before entering in lab.
7. Switch off the lights, fans and all the equipments used, before leaving lab.
8. Students will replace their chairs to its specific position before leaving the lab

LIST OF EXPERIMENTS

	NAME OF EXPERIMENTS	CO	Page NO
1	Study of universal testing machine and determination of Young's Modulus of mild steel	C215.1	8-12
2	Compression testing on CI, Wood, and concrete cubes by compression testing machine.	C215.2	
3	Determination of bending stress in beam using gauge.	C215.3	
4	Determination of hardness of different metals.	C215.3	
5	Determination of impact strength of ductile material.	C215.3	
6	Machine shop practice	C215.5	
7	Study of internal combustion engines.		
8	Determination of MA, VR and Efficiency for screw Jack.	C215.4	
9	Moment of Inertia of a flywheel.		
10	Study of different types of Governors (Watt, porter and Hartnell)	C215.1	

DOs and DON'Ts

DOs

1. Work deliberately and carefully.
2. Keep your work area clean.
3. Students must wear college uniform and carry their college ID.
4. Students should have separate note book for practical.
5. Students should have their own pencil, eraser, scale, along with pen and lab note book.
6. Handle the equipment /models carefully.

DON'Ts

1. Do not wander around the room, distract other students, startle other students or interfere with the laboratory experiments of others.
2. Do not eat food, drink beverages or chew gum in the laboratory.
3. Do not open any irrelevant internet sites on lab computer.

EXPERIMENT No. 1**TENSION TEST**

AIM: Study of Universal Testing Machine and determination of Young's Modulus of mild steel

OBJECT: To conduct a tensile test on a mild steel specimen and determine the following:

- (i) Limit of proportionality
- (ii) Elastic limit
- (iii) Yield strength
- (iv) Ultimate strength
- (v) Young's modulus of elasticity
- (vi) Percentage elongation
- (vii) Percentage reduction in area.

APPARATUS:

- (i) Universal Testing Machine (UTM)
- (ii) Mild steel specimens
- (iii) Graph paper
- (iv) Scale
- (v) Vernier Caliper

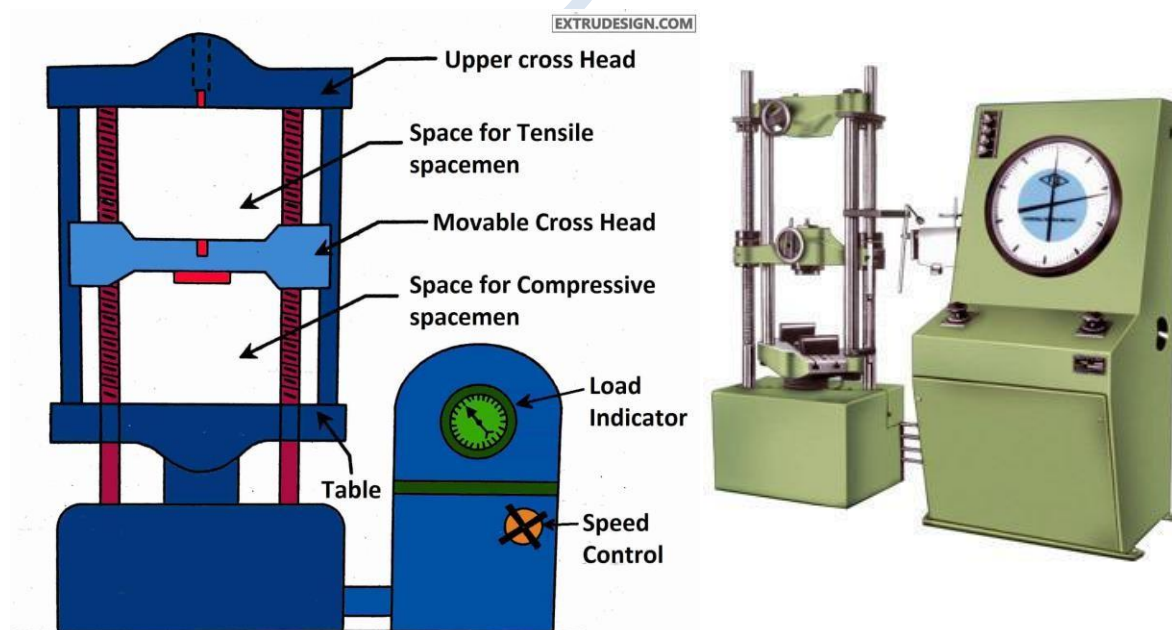
DIAGRAM:

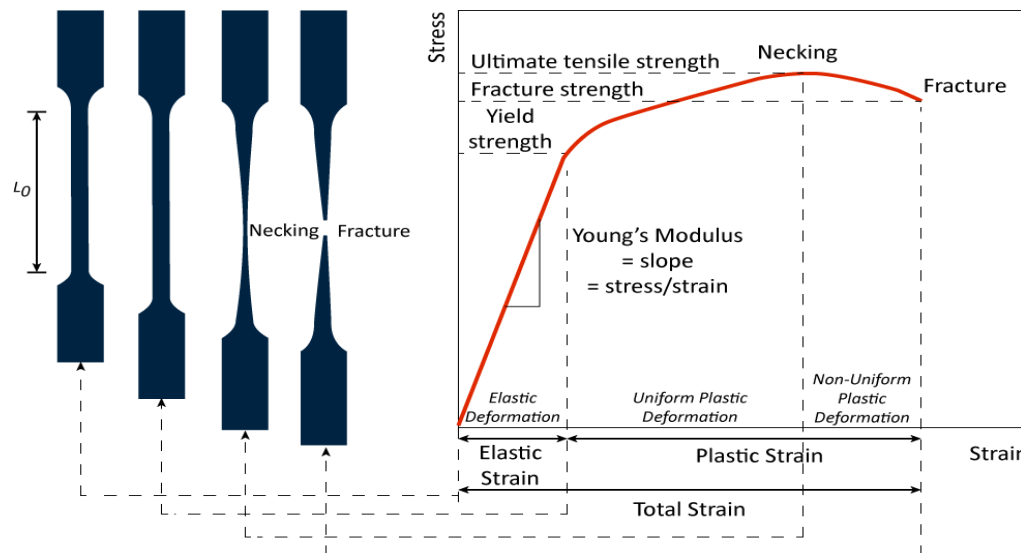

THEORY:

The tensile test is most applied one, of all mechanical tests. In this test ends of test piece are fixed into grips connected to a straining device and to a load measuring device. If the applied load is small enough, the deformation of any solid body is entirely elastic. An elastically deformed solid will return to its original form as soon as load is removed. However, if the load is too large, the material can be deformed permanently. The initial part of the tension curve which is recoverable immediately after unloading is termed. As elastic and the rest of the curve which represents the manner in which solid undergoes plastic deformation is termed plastic. The stress below which the deformations essentially entirely elastic is known as the yield strength of material. In some material the onset of plastic deformation is denoted by a sudden drop in load indicating both an upper and a lower yield point. However, some materials do not exhibit a sharp yield point. During plastic deformation, at larger extensions strain hardening cannot compensate for the decrease in section and thus the load passes through a maximum and then begins to decrease. This stage the “ultimate strength” which is defined as the ratio of the load on the specimen to original cross-sectional area, reaches a maximum value. Further loading will eventually cause ‘neck’ formation and rupture.

About of UTM

The tensile test is conducted on UTM. It is hydraulically operates a pump, oil in oil sump, load dial indicator and central buttons. The left has upper, middle and lower cross heads i.e; specimen grips (or jaws). Idle cross head can be moved up and down for adjustment. The pipes connecting the lift and right parts are oil pipes through which the pumped oil under pressure flows on left parts to move the cross-heads.

SPECIFICATIONS:

1. Load capacity = 0-40 Tones.
2. Least count = 8 kgf.
3. Overall dimension. =
4. Power supply = 440 V

PROCEDURE:

1. Measure the original length and diameter of the specimen. The length may either be length of gauge section which is marked on the specimen with a preset punch or the total length of the specimen
2. Insert the specimen into grips of the test machine and attach strain-measuring device to it
3. Begin the load application and record load versus elongation data.
4. Take readings more frequently as yield point is approached.
5. Measure elongation values with the help of dividers and a ruler.
6. Continue the test till Fracture occurs.
7. By joining the two broken halves of the specimen together, measure the final length and diameter of specimen.

OBSEVATION:

- | | |
|--|------------------|
| (a) Initial diameter of specimen | d1 = |
| (b) Initial gauge length of specimen | L1 = |
| (c) Initial cross-section area of specimen | A1 = |
| (d) Load of yield point | F _t = |
| (e) Ultimate load after specimen breaking | F = |
| (f) Final length after specimen breaking | L ₂ = |
| (g) Diameter of specimen at breaking place | d2 = |

(h) Cross section area at breaking place $A_2 =$

OBSERVATION TABLE:

S.No	Load (N)	Original Gauge Length	Extension (mm)	Stress (N/mm ²)	Strain

CALCULATION:

- Ultimate tensile strength = $\dots\dots\dots \frac{N}{mm^2}$
- Elastic limit = $\frac{\text{Load at elastic limit}}{\text{original area of cross section}} = \dots\dots\dots \frac{N}{mm^2}$
- (iii) Modulus of Elasticity (E) = $\frac{\text{stress below proportional limit}}{\text{corresponding strain}} = \dots\dots\dots \frac{N}{mm^2}$
- (iv) Yield Strength = $\frac{\text{yield load}}{\text{original cross sectional area}} = \dots\dots\dots \frac{N}{mm^2}$
- % Reduction in area = $\frac{A_f - A_i}{A_i} \times 100 = \dots\dots\dots \%$
- Percentage of elongation = $\frac{l_i - l_f}{l_f} \times 100 = \dots\dots\dots \%$
- Limit of Propagation = $\frac{\text{Load at limit of proportionality}}{\text{original cross sectional area}}$
- Stress = $\sigma = \frac{\text{Load}}{\text{Area}} = \frac{P}{A} \dots\dots\dots \frac{N}{mm^2}$
- Strain = $\epsilon = \frac{\text{change in length}}{\text{original length}} = \dots\dots\dots$
- Young's modulus = $E = \frac{\text{stress}}{\text{strain}} \dots\dots\dots \frac{N}{mm^2}$

PRECAUTIONS:

1. The specimen should be prepared in proper dimensions.
2. The specimen should be properly to get between the jaws.
3. Take reading carefully.
4. After breaking specimen stop to m/c.

RESULT:

(i) Average Breaking Stress =

(ii) Ultimate Stress =

(iii) Average % Elongation =

VIVA-QUESTIONS

1. Which steel have you tested? What is its carbon content?
2. What general information is obtained from tensile test regarding the properties of a material?
3. Which stress have you calculated: nominal stress or true stress?
4. What kind of fracture has occurred in the tensile specimen and why?
5. Which is the most ductile metal? How much is its elongation

APPLICATIONS:

1. In Aerospace
2. Automotive
3. Packaging
4. sports

Experiment no-2**COMPRESSION TEST ON WOOD**

AIM: To determine the compressive strength of wood in given sample material.

Apparatus required:

Compressometer (or) Compression Testing Machine, Wooden specimen.



Procedure:

1. Calculate the material required for preparing the wood of given specification.
2. Immediately after being made, they should be covered with wet mats.
3. Compression tests of wood specimens are made as soon as practicable after removal from making factory. Test-specimen during the period of their removal from the making factory and till testing, are kept moist by a wet blanket covering and tested in a moist condition.
4. Place the specimen centrally on the location marks of the compression testing machine and load is applied continuously, uniformly and without shock.

5. Also note the type of failure and appearance cracks.

Formula used:

$$\text{The compressive strength of wooden specimen} = \frac{\text{Taking compressive load}}{\text{Cross sectional area}}$$

Observation and Tabulation:

Specimen	Trial		Mean value N/mm ²
	1	2	
Load on wood.KN			

Result:

The compressive stress of the wooden specimen = -----N/mm²

EXPERIMENT No. 3

AIM: Determine of bending stress of cantilever beam.

APPARATUS:

Beam apparatus, Bending fixture, vernier caliper, meter rod, test piece & dial gauge.

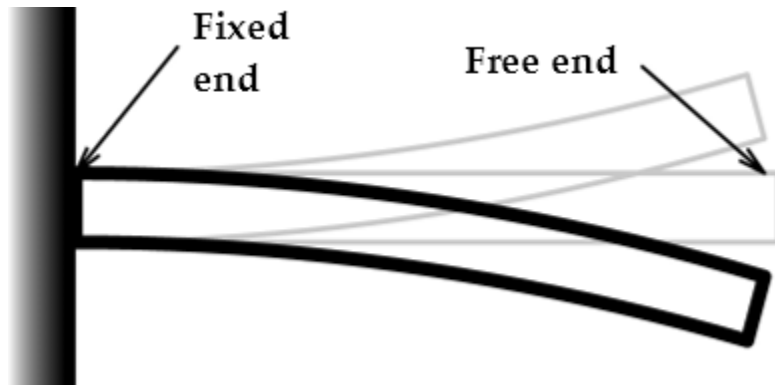
DIAGRAM:**THEORY:**

A Cantilever is a Beam one end of which is clamped and other end is free. A beam with a length L and is fixed at one end and the other end is free. Let the moment of inertia of the Beam is ' I ' about its neutral axis and the Young's Modulus be ' E '.

Moment of inertia about the neutral axis

$$I = \frac{bh^3}{12}$$

Deflection at the end where point load is acting = δ

The deflection at the end (Max deflection) δ is related to the load ' W ', length ' L ' moment of Inertia ' I ' and Young's Modulus ' E ' through the equation.

$$\delta = \frac{WL^3}{3EI}$$

PROCEDURE:

1. Clamp the Beam horizontally on the clamping support at one end.
2. Measure the length of cantilever L (distance from clamp end to loading point)
3. Fix the dial gauge under the beam at the loading point to Read down-ward Moment and set o zero.
4. Hang the loading Pan at the free end of the cantilever.
5. Load the cantilever with different loads (W) and note the dial gauge readings (δ)
6. Change the length of cantilever for two more different lengths repeat the Experiment.
7. Change the position of cantilever and repeat he experiment for the other value of I for rectangular cross-section.

TABLE:

S.No	Load 'W' in N	Deflection ' δ ' in mm.	Young's Modulus 'E' $\frac{N}{mm^2}$

CALCULATIONS:

$$1. \quad I = \frac{b h^3}{12}$$

$$2. \quad \delta = \frac{WL^3}{3EI}$$

PRECAUTIONS:

1. The length of the cantilever should be measured properly.
2. The dial gauge spindle knob should always touch the beam at the bottom of loading point.
3. Loading hanger should be placed at known distance of cantilever length.
4. Al the errors should be eliminated while taking readings.
5. Elastic limit of the Beam should not exceed.
6. Beam should be positioned horizontally.

RESULT: The Bending strength of given specimen = $\frac{N}{mm^2}$

VIVA QUESTIONS:

1. Cantilever beam means?
2. What is the deflection formula of cantilever beam?
3. What is the difference between cantilever and simply supported beam?
4. Write types of loads?
5. Contra flexure means?

APPLICATIONS:

1. In aircraft



2. Cantilever Cranes



EXPERIMENT No. 3

AIM: Determine bending stress of simply supported beam.

APPARATUS:

Beam apparatus, Bending fixture, vernier caliper, meter rod, test piece & dial gauge.

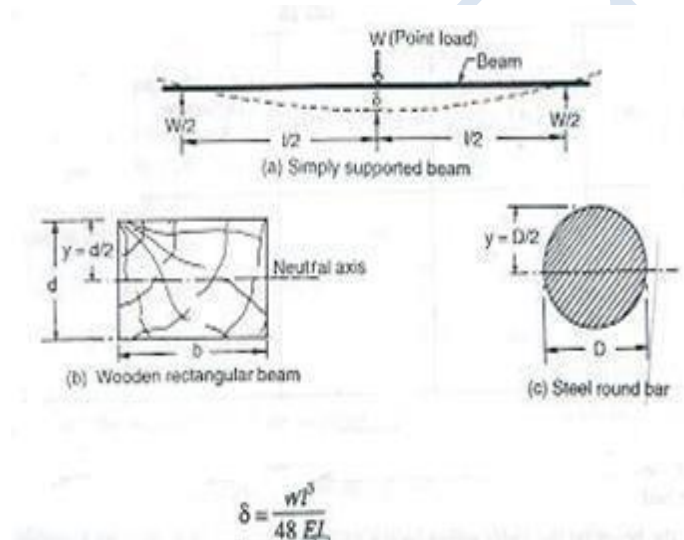
DIAGRAM:**THEORY:**

Bending test is performed on a beam by using the three-point loading system. The bending fixture is supported on the platform of a hydraulic cylinder of the UTM. The loading is held in the middle cross head. At a particular load, the deflection at the center of the beam is determined by using a dial gauge. The deflection at the beam center is given by:

$$\delta = \frac{WL^3}{48EI}$$

PROCEDURE:

1. Measure the length, width and thickness of test piece, by vernier caliper.
2. Place the bending fixture on the lower cross head of the testing machine.
3. Place the test piece on the rollers of the bending fixture.
4. By loading the dial gauge in a stand, make its spindle knob touch the test piece.

5. Start the m/c and note down the load and dial gauge readings.
6. Plot the graph between load and deflection.

OBSERVATIONS:

1. Least count of vernier caliper = -----
2. Length of beam (L) = -----
3. Width of beam (b) = -----
4. Thickness of beam (t) = -----

TABLE:

S.No	Load 'W' in N	Deflection 'δ' in mm.	Young's Modulus 'E' $\frac{N}{mm^2}$

CALCULATIONS:

$$1. \quad I = \frac{b t^3}{12}$$

$$2. \quad \delta = \frac{WL^3}{48EI}$$

PRECAUTIONS:

1. The length of the simply supported should be measured properly.
2. The dial gauge spindle knob should always touch the beam at the bottom of loading point.
3. Loading hanger should be placed at known distance
4. All the errors should be eliminated while taking readings.
5. Beam should be positioned horizontally.

RESULT:

The Bending strength of given specimen = $\frac{N}{mm^2}$

VIVA QUESTIONS

1. Types of beams.
2. What is deflection?
3. Write the equation for the Slope for a cantilever beam with point load
4. Write the deflection equation for the simply supported beam with point load at the center
5. How many types of bending are there?

APPLICATIONS:

1. for construction of bridges



EXPERIMENT No. 4 (A)**BRINELL HARDNESS TEST**

AIM: To determine the hardness of the given specimen using Brinell hardness test.

APPARATUS: Brinell hardness testing machine, Aluminum specimen, Ball indenter.

DIAGRAM:

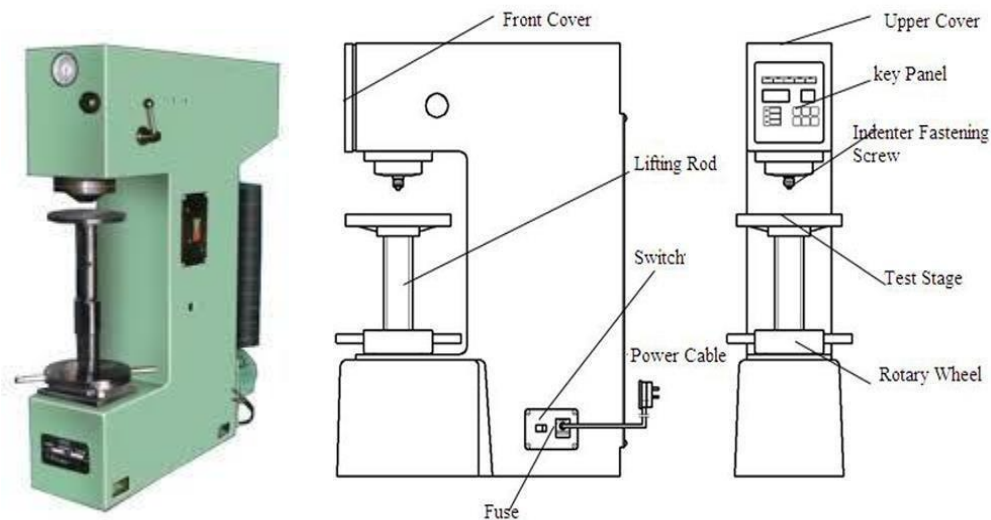
**THEORY:**

In Brinell hardness test, a steel ball of diameter (D) is forced under a load (F) on to a surface of test specimen. Mean diameter (d) of indentation is measured after the removal of the load (F).

Its specifications as follows:

1. Ability to determine hardness up to 500BHN.
2. Diameter of ball (as indenter) used $D = 2.5\text{mm}, 5\text{mm}, 10\text{mm}$.
3. Maximum application load = 3000kgf
4. Method of load application = Lever type
5. Capability of testing the lower hardness range = 1BHN on application of $0.5D^2$ load.

PROCEDURE:

1. Insert ball of diameter ' D ' in the ball holder of machine.
2. Make the specimen surface clean by oil, grease, dust etc.
3. Make contact between the specimen surface and ball using jack adjusting wheel.
4. Push the required button for loading.

5. Pull the load release level and wait for 15 seconds.
6. Remove the specimen from the support table and locate the Indentation.
7. View the indentation through microscope and measure the diameter 'd' of the indentation using micrometer fixed on the microscope.
8. Repeat the procedure and take three readings.

OBSERVATIONS:

Test piece material =

Diameter of the ball D =

Load section F/D^2 =

Test load =

Load application time =

Least count of Brinell Microscope =

S.NO	Ball Diameter D in mm	Load applied F in kgf	Diameter of indentation	$\frac{P}{D^2}$	

$$\text{BHN} = \frac{\text{Load Applied (kgf)}}{\text{spherical surface area of indentation}}$$

$$\text{BHN} = \frac{2P}{\pi D(D - \sqrt{D^2 - d^2})}$$

PRECAUTION:

1. Make sure that beam and load placed a proper position.
2. The cross- section of the beam should be large.
3. Note down the readings more carefully..

VIVA QUESTIONS:

1. How to measure the hardness
2. What are the formulae of BHN?
3. Which ball size is recommended for Brinell test?
4. What is the difference between the brinell and Rockwell hardness test?
5. For steel ultimate tensile strength =----- BHN?

APPLICATIONS:

1. In manufacturing Industries



2. Bearing Manufacturing industries



EXPERIMENT No. 4 (B)

ROCKWELL HARDNESS TESTER

AIM: To determine the hardness of the given Specimen using Rockwell hardness test.

APPARATUS: Rockwell hardness testing machine,

MATERIAL: soft and hard mild steel specimens, brass, Aluminum etc., Black diamond cone indenter.

DIAGRAM:

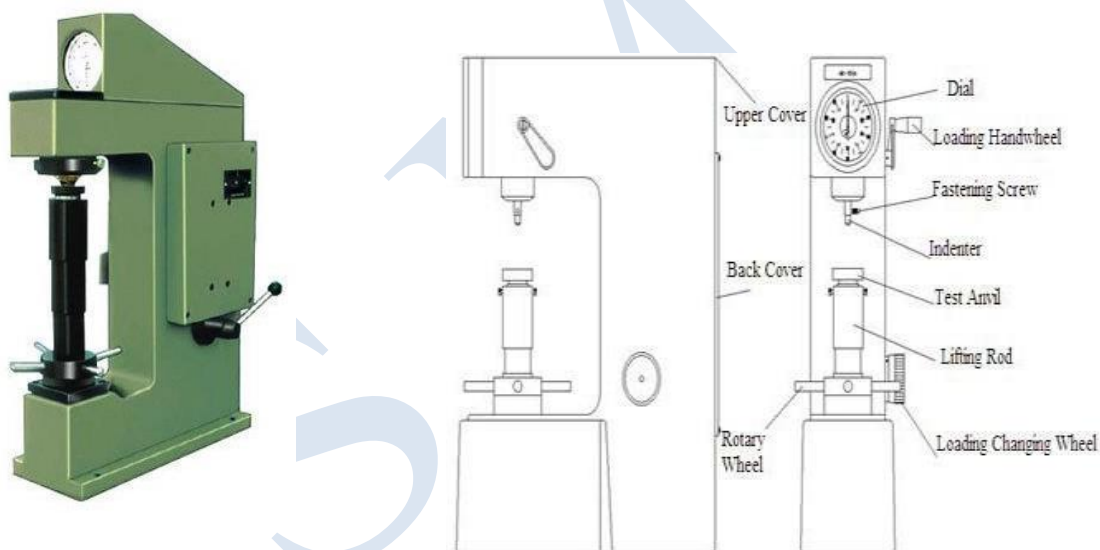

THEORY:

Rockwell test is developed by the Wilson instrument co U.S.A in 1920. This test is an indentation test used for smaller specimens and harder materials. The test is subject of IS: 1586. The hardness of a material is resistance to penetration under a localized pressure or resistance to abrasion. Hardness tests provide an accurate, rapid and economical way of determining the resistance of materials to deformation.

There are three general types of hardness measurements depending upon the manner in which the test is conducted:

- a. Scratch hardness measurement,
- b. Rebound hardness measurement
- c. Indention hardness measurement.

In scratch hardness method the material are rated on their ability to scratch one another and it is usually used by mineralogists only. In rebound hardness measurement, a standard body is usually dropped on to the material surface and the hardness is measured in terms of the height of its rebound .The general means of judging the hardness is measuring the resistance of a material to indentation. The indenters usually a ball cone or pyramid of a material much harder than that being used. Hardened steel, sintered tungsten carbide or diamond indenters are generally used in

PROCEDURE:

1. Examine hardness testing machine (fig.1)
2. Place the specimen on platform of a machine. Using the elevating screw raise the platform and bring the specimen just in contact with the ball. Apply an initial load until the small pointer shows red mark.
3. Release the operating valve to apply additional load. Immediately after the additional load applied, bring back operating valve to its position.
4. Read the position of the pointer on the C scale, which gives the hardness number.
5. Repeat the procedure five times on the specimen selecting different points for indentation.

OBSERVATION TABLE:

S.NO	Specimens	Reading (HRC/)			Mean
		1	2	3	
1	Mild Steel				HRB =
2	High Carbon steel				HRC =
3	Brass				HRB =
4	Aluminum				HRB =

PRECAUTIONS:

1. The specimen should be clean properly
2. Take reading more carefully and
3. The test should not be made on specimens so thin that the impression shows through the metal, nor should impression be made too close to the edge of a specimen.

VIVA QUESTIONS:

1. Define Hardness
2. Size of the Ball to be used in Ball Indenter of Rockwell Hardness Test.
3. Different Types of Hardness Testing Methods.
4. Applications of Rockwell Hardness A – Scale, B-Scale, C-Scale
5. In Rockwell hardness test the hardness is measured by?

APPLICATIONS:

1. In manufacturing Industries



2. Bearing Manufacturing industries

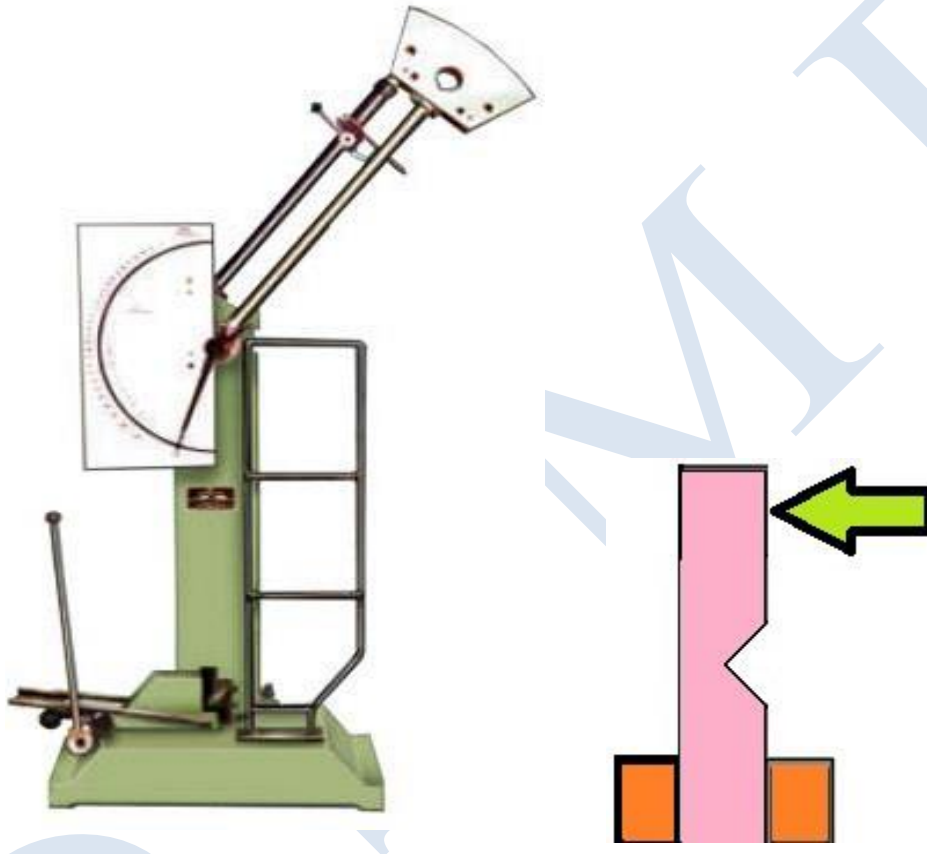

EXPERIMENT No. 5 (A)**IZOD IMPACT TEST****AIM:** Determination of impact strength of ductile materials**APARATUS:** Impact testing machine, MS Specimen**DIAGRAM:****PROCEDURE:**

1. For conducting charpy test, a proper striker is to be fitted firmly to the bottom of the hammer with the help of the clamping piece.
2. The latching take for charpy test is to be firmly fitted to the bearing housing at the side of the columns.
3. The frictional loss of the machine can be determined by free fall test, raise the hammer by hands and latch in release the hammer by operating lever the pointer will then indicate the energy loss due to friction. From this reading confirm that the friction loss not exceeding 0.5% of the initial potential energy. Otherwise frictional loss has to be added to the final reading.

4. The specimen for izod test is firmly fitted in the specimen support with the help of clamping screw and élan key. Care should be taken that the notch on the specimen should face to pendulum striker.
5. After ascertaining that there is no person in the range of swinging pendulum, release them pendulum to smash the specimen.
6. Carefully operate the pendulum brake when returning after one swing to stop the oscillations.
7. Read-off position of reading pointer on dial and note indicated value.
8. Remove the broken specimen by loosening the clamping screw.

The notch impact strength depends largely on the shape of the specimen and the notch. the values determined with other specimens therefore may not be compared with each other.

TABLE:

S.NO	Area of cross section specimen (A)	Impact Energy (K)	I (Impact strength)

PRECAUTIONS:

1. Measure the dimensions of the specimen carefully.
2. Locate the specimen in such a way that the hammer. Strikes it at the middle.
3. Note down readings carefully.

RESULT:

The Impact strength of the given specimen is ----- $\frac{J}{m^2}$

VIVA QUESTIONS:

1. In what way the values of impact energy will be influenced if the impact tests are conducted on two specimens, one having smooth surface and the other having scratches on the surface
2. What is the effect of temp? On the values of rupture energy and notch impact strength?
3. What is resilience? How is it different from proof resilience and toughness?
4. What is the necessity of making a notch in impact test specimen?
5. If the sharpness of V-notch is more in one specimen than the other, what will be its effect on the test result ?

APPLICATIONS:

1. in forging industry.



2. in the rubber industry.

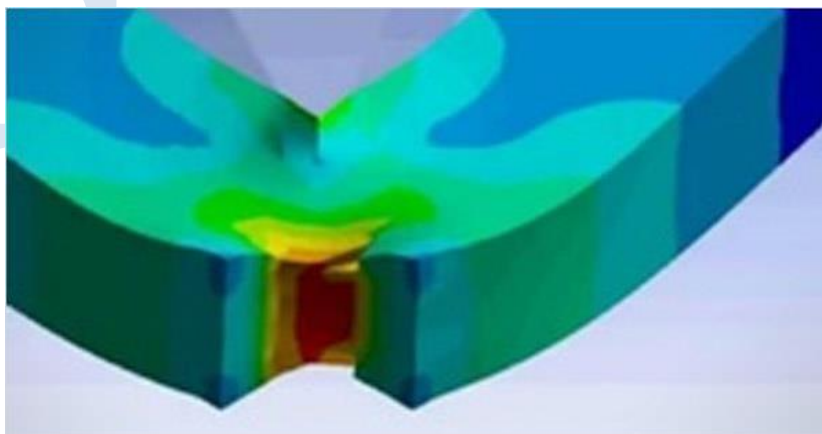

EXPERIMENT No. 5 (B)**CHARPY IMPACT TEST ON METAL SPECIMEN**

AIM: Determination of impact strength of ductile materials

APPARATUS:

Izod Impact test machine, test specimen, Vernier calipers, and steel rule.

IMPACT STRENGTH: The resistance of a material to fracture under sudden load Application.

MATERIALS: Mild steel (Square test pieces)

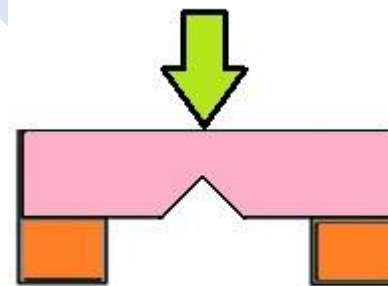
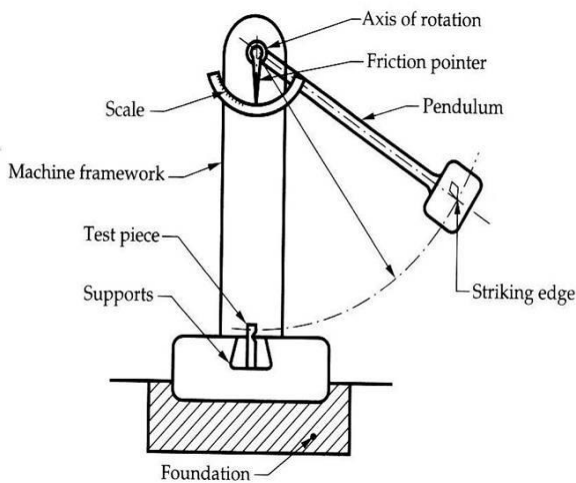

(b) Charpy Test

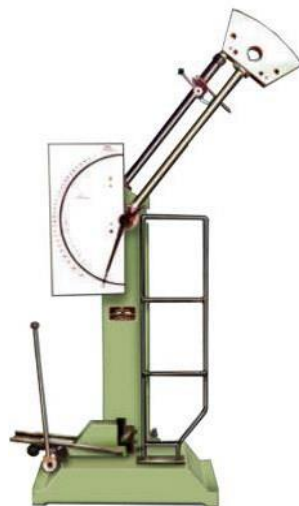

THEORY:

An impact test signifies toughness of material that is ability of material to absorb energy during plastic deformation. The type of test specimen used for this test is a Square Cross-section. The specimen may have single, two or three notches.

The testing machine should have the following specifications.

- The angle θ between top face of grips and face holding the specimen vertical = 90° The angle of tip of hammer = $75^\circ \pm 1^\circ$
- The angle between normal to the specimen and underside face of the hammer at striking point = $10^\circ \pm 1^\circ$
- Speed of hammer at impact = 3.99 m/sec
- Striking energy = 168 N-m or Joules
- Angle of drop θ of pendulum = 90°
- Effective weight of pendulum = 21.79 kg
- Minimum value of scale graduation = 2 Joules.
- Permissible total friction loss of corresponding energy = 0.50%
- Distance from the axis of rotation of distance between the base of specimen notch and the point of specimen hit by the hammer = $22\text{mm} \pm 0.5\text{mm}$

The longitudinal axes of the test piece shall lie in the plane of swing of the center of gravity of the hammer. The notch shall be positioned so that it is in the plane of the hammer. The notch shall be positioned its plane of symmetry coincides with the top face of the grips. For setting the specimen the notch impact strength I is calculated according to the following relation.

Where I = impact strength in joules/m²

PROCEDURE:

1. For conducting Charpy test, a proper striker is to be fitted firmly to the bottom of the hammer with the help of the clamping piece.
2. The latching take for Charpy test is to be firmly fitted to the bearing housing at the side of the columns.
3. The frictional loss of the machine can be determined by free fall test, raise the hammer by hands and latch in release the hammer by operating lever the pointer will

then indicate the energy loss due to friction. From this reading confirm that the friction loss not exceeding 0.5% of the initial potential energy. Otherwise frictional loss has to be added to the final reading.

4. The specimen for izod test is firmly fitted in the specimen support with the help of clamping screw and élan key. Care should be taken that the notch on the specimen should face to pendulum striker.
5. After ascertaining that there is no person in the range of swinging pendulum, release them pendulum to smash the specimen.
6. Carefully operate the pendulum brake when returning after one swing to stop the oscillations.
7. Read-off position of reading pointer on dial and note indicated value.
8. Remove the broken specimen by loosening the clamping screw.
9. The notch impact strength depends largely on the shape of the specimen and the notch. The values determined with other specimens therefore may not be compared with each other.

TABLE:

S.NO	Area of cross section specimen (A)	Impact Energy (K)	I (Impact strength)

PRECAUTIONS:

1. Measure the dimensions of the specimen carefully.
2. Locate the specimen (Charpy test) in such a way that the hammer. Strikes it at the middle.
3. Note down readings carefully.

RESULT: The Impact strength of material by Charpy test.....

VIVA QUESTIONS:

1. What is resilience? How is it different from proof resilience and toughness?

2. The ability of the material to resist stress without failure is called?
3. The impact test is done to test _____ of a material?
4. In Charpy impact test, the specimen is kept as _____?
5. In Charpy test specimen, the angle of v-notch section is?

APPLICATIONS:

In forging industry:

The Charpy impact test can be used to determine the malleability and ductility of a material that is being forged.



In plastic industry,

The test is used for analyzing the breaking strength of a sample when it is subjected to a high impact from a pendulum. This helps in ensuring that the material is best for an application where it is subjected to such impacts.

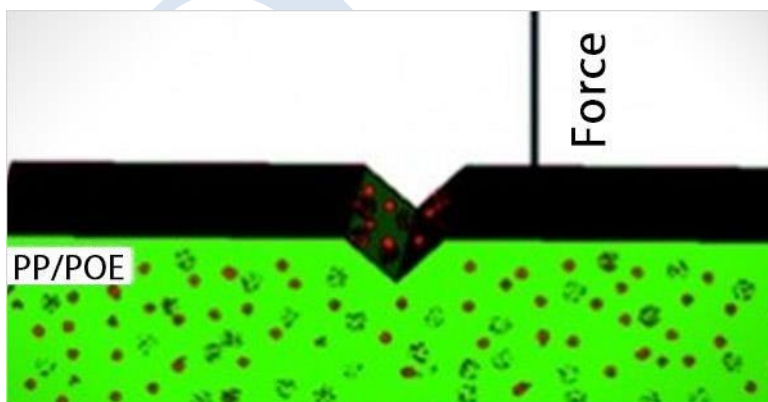

Experiment No- 6

MACHINE SHOP

1.1 Introduction to Machine shop

A place where hand tools and power-driven tools are used for making, finishing, or repairing machines or machine parts or in other words a facility that has machines, machine tools for working with metal other relatively hard materials such as some ferrous and non ferrous, composites, polymers, etc,. Various kinds of machine shops make and repair all types of metal objects from machine tools, dies and molds etc.

1.2 Introduction to Machining:

The machining is the broadest technological process used in manufacturing. Generally, in the field of manufacturing, the term of Machining means removal of material from a raw material, by cutting small chips, in order to obtain the desired shape and dimensions for final part. The machining is strictly necessary when finished Part has to have very tight tolerances of Dimensions or when the roughness of surfaces Need to be very smooth.

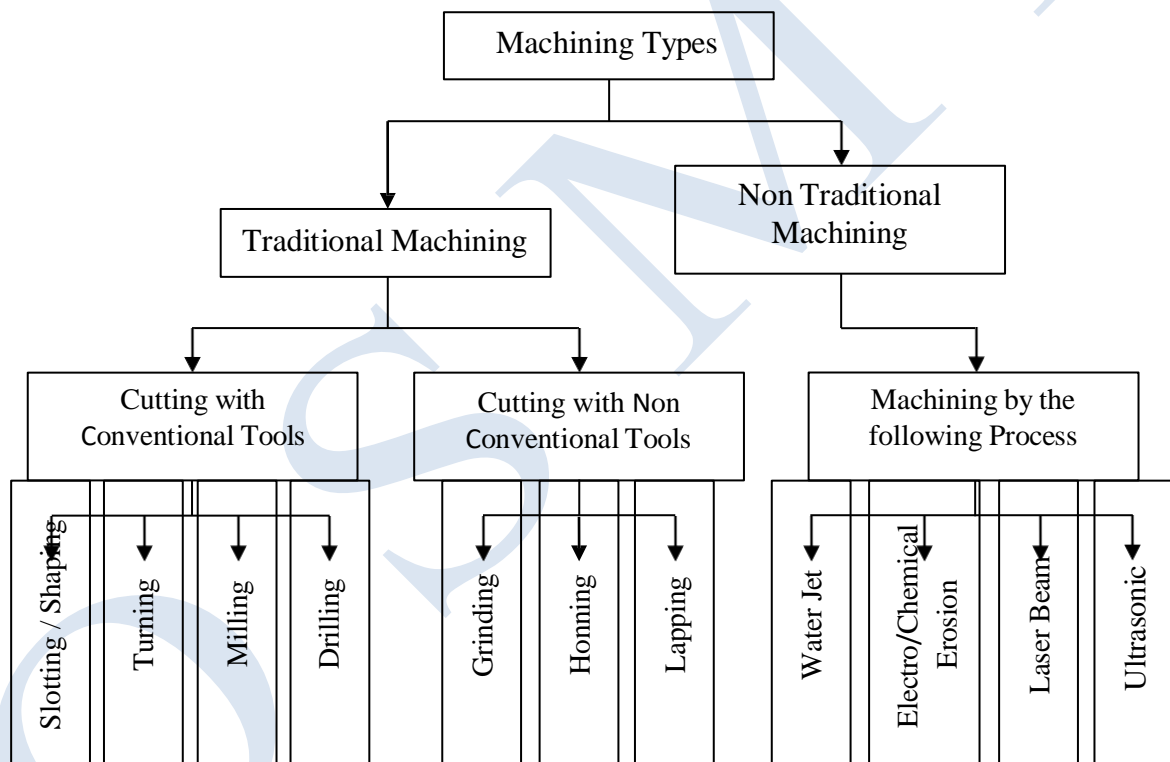

Fig.1 Synoptically Classification

1.3 Machine Tool:

Machine tool is a non-portable power operated device in which the energy is utilized to produce jobs of desired shape and size and surface finish by removing excess material from the formed blanks in the form of chips with the help of cutting tools moved part the work surface.

It is machining equipment that cuts, shears, punches, presses, drills, rolls, grinds, sands, or forms metal, plastic, or wood stock. It may be automatic or semi-automatic.

Machine tools are generally power- driven metal cutting or forming machines used to shape metals by:

- The removal of chips

- Pressing drawing or shearing
- Controlled electrical machining process
- Any machine tool has generally has capability of
- Holding and supporting the work piece
- Holding and supporting a cutting tool
- Imparting a suitable movement (rotating or reciprocating) to the cutting tool or the work
- Feeding the cutting tool so that the desired cutting action and accuracy will be achieved
- The performance of any machine tool is generally stated in terms of its metal removal rate, accuracy and repeatability.

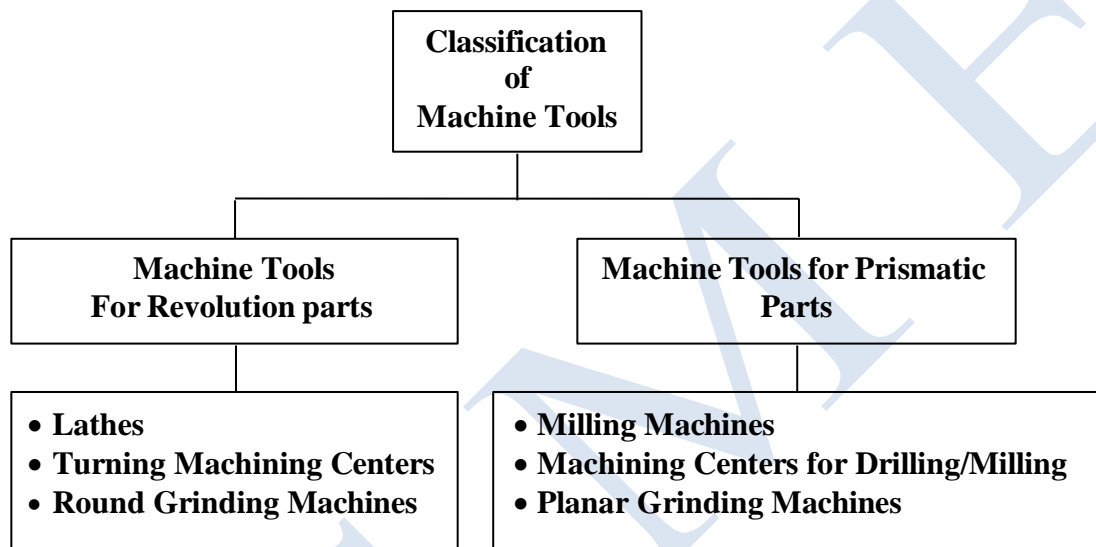

1.4 Cutting Tool

A tool is a device or a piece of equipment which typically provides a mechanical advantage in accomplishing a physical task, or provides an ability that is not naturally available to the user of a tool. These tools are hand-held, portable powers, or manual tools.

The differences are stated below:

Cutting Tools	Machine Tools
1. Tool is a portable device 2. Tool is a non-powered device 3. Tool can only powered by humans Examples: Turning, shaping, drilling, milling tools, Hammers, wrenches, saws and shovels, pens, pencils and knives are tools.	1. It is a stationary device 2. It is a powered device 3. It is powered by a power source or by people if properly setup. Examples: Lathes, shapers, planers, power drills or drill presses, milling machines, grinding machines, power saws, and presses (e.g., punch presses).

1.5 Tool Materials

The various tool materials used in today's manufacturing operations are high-carbon steel, high-speed steel, cemented carbides, ceramics, diamond & cubic boron nitride (CBN).

Types of Tool Materials:

- ✓ High Carbon steels
- ✓ High Speed Steels
- ✓ Cemented Carbides
- ✓ Medium Alloy steels
- ✓ Abrasives
- ✓ Diamonds
- ✓ Stellite Ceramics

1.5.1 High Carbon Steel

This material is one of the earliest cutting materials used in machining. It is however now virtually superseded by other materials used in engineering because it starts to temper at about 220°C. This softening process continues as the temperature rises. As a result cutting using this material for tools is limited to speeds up to 0.15 m/s for machining mild steel with lots of coolant. High carbon steels are oil- or water-hardened plain carbon steels with 0.9 to 1.4 percent carbon content. They are used for hand tools such as files and chisels, and only to a limited extent for drilling & turning tools. They impart such properties to tools made from them that such tools maintain a keep edge & can be used for metals that can be used for such metals that produce low tool-chip interface temperatures-for example, aluminum, magnesium, copper, and brass. These tools, however, tend to soften at machining speeds above 50 feet per minute (fpm) in mild steels.

1.5.2 High Speed Steel (HSS)

This range of metal contains about 7% carbon, 4% chromium plus additions of tungsten, vanadium, molybdenum and cobalt. These metals maintain their hardness at temperature up to about 600, but soften rapidly at higher temperatures. These materials are suitable for cutting mild steel at speeds up maximum rates of 0.8 m/s to 1.8 m/s. High-speed steel may be used at higher cutting speeds (100 fpm in mild 20 steels) without losing their hardness. High-speed steel is sometimes used for lathe tools when special tool shapes are needed, especially for boring tools. However, high-speed steel is extensively used for milling cutters. These cutters usually have a longer working life.

1.5.3 Cast Alloys

These cutting tools are made of various nonferrous metals in a cobalt base. They can withstand cutting temperatures of up to 760°C and are capable of cutting speeds about 60% higher than HSS.

1.5.4 Stellite

This is a cast alloy of Co (40 to 50%), Cr (27 to 32%), W (14 to 19%) and C (2%). Stellite is quite tough and more heat and wear resistive than the basic HSS (18 – 4 – 1) But such stellite as cutting tool material became obsolete for its poor grindability and especially after the arrival of cemented carbides.

1.5.5 Cemented carbides (Cermets or Sintered Carbide)

Carbide, generally, is a chemical compound of carbon and a metal. This material usually consists of tungsten carbide or a mixture of tungsten carbide, titanium, or tantalum carbide in powder form, sintered in a matrix of cobalt or nickel. The term Carbide is commonly used to re-present to cemented carbides, the cutting tools composed of tungsten carbide, titanium carbide, or tantalum carbide & cobalt in various combinations. A typical composition of cemented carbide is 85 to 95 percent of tungsten & the remainder a cobalt binder for the tungsten carbide powder. Cemented carbides are extremely hard tool materials (above RA 90), have a high compressive strength & resist wear & rupture. Coated carbide inserts are often used to cut hard or difficult-to-machine work pieces. Titanium carbide (TiC) coating offers high wear resistance at moderate cutting speeds and temperatures. Aluminum oxide (Al₂O₃) coating has high resistance to crater wear and reduces friction between the tool face and the chip, thereby reducing the tendency for built-up edge.

Cemented carbides are the most widely used tool materials in the machining industry. They are particularly useful for cutting tough alloy steels, which quickly break down high-speed tool

steels. As this material is expensive and has low rupture strength it is normally made in the form of tips which are brazed or clamped on a steel shank. The clamped tips are generally used as throw away inserts.

1.5.6 Coated Carbides

The cutting system is based on providing a thin layer of high wear-resistant titanium carbide fused to a conventional tough grade carbide insert, thus achieving a tool combining the wear resistance of one material with the wear resistance of another. These systems provide a longer wear resistance and a higher cutting speed compared to conventional carbides.

1.5.7 Ceramics

Ceramic or “cemented oxide” tools are made primarily from aluminum oxide. Ceramics are made by powder metallurgy from aluminium oxide with additions of titanium oxide and magnesium oxide to improve cutting properties. Some manufacturers add titanium, magnesium, or chromium oxides in quantities of 10% or less. The tool materials are molded at pressures over 4000 psi and sintered at temperatures of approximately 3000oF. This process partly accounts for the high density and hardness of cemented oxide tools. These have a very high hot resistance and wear resistance and can cut at very high speed. However they are brittle and have little resistance to shock. Their use is therefore limited to tips used for continuous high speed cutting on vibration-free machines. Cemented oxides setups are rigid and free of vibration and are used as a replacement for carbide tools that are wearing rapidly, but not to replace carbide tools that are breaking.

1.5.8 Diamonds Tools

Diamonds have limited application due to the high cost and the small size of the stones. They are used on very hard materials to produce a fine finish and on soft materials especially those inclined to clog other cutting materials. They are generally used at very high cutting speed with low feed and light cuts. Due to the brittleness of the diamonds the machine has to be designed to be vibration free. The tools last for 10 (up to 400) times longer than carbide based tools. Industrial diamonds are sometimes used to machine extremely hard work pieces. Only relatively small removal rates are possible with diamond tools, but high speeds are used and good finishes are obtained. Diamond tools are particularly effective for cutting abrasive materials that quickly wear out other tool materials. Nonferrous metals, plastics, and some nonmetallic materials are often cut with diamond tools.

1.5.9 Cubic Boron Nitride (CBN)

CBN is next to diamond in hardness and therefore can be used to machine plain carbon steels, alloy steels, and gray cast irons with hardness's of 45 RC and above. CBN inserts consist of a cemented carbide substrate with an outside layer of CBN formed as an integral part of the tool. Tool life, finishes, and resistance to cracking and abrasion make CBN a superior tool material to both carbides and ceramics.

1.5.10 Abrasive:

Abrasive grains in various forms loose bonded into wheels and stone and embedded in papers and cloths find wide application in industry. They are mainly used for grinding harder materials and where a superior finish is desired on hardened or unhardened materials.

1.5.11 Elements of an Effective Tool:

- | | |
|--|------------------------|
| ✓ High hardness at elevated temperatures | ✓ Wear resistance |
| ✓ Strength to resist bulk deformation | ✓ Consistent tool life |
| ✓ Adequate thermal properties | ✓ Correct geometry |
| ✓ Consistent tool life | ✓ Chemical stability |

1.5.12 There are 2 types of cutting tools

a) Single Point Cutting Tool:

The tool generally refers to a non-rotary cutting tool used in metal lathes, shapers, and planers. Such cutters are also often referred to by the set-phrase name of single-point cutting tool. The cutting edge is ground to suit a particular machining operation and may be resharpened or reshaped as needed. The ground tool bit is held rigidly by a tool holder while it is cutting. Single-point tools are used in turning, shaping and planing operations and similar operations to remove material by means of one cutting edge.

Cutting tools must be made of a material harder than the material which is to be cut, and the tool must be able to withstand the heat generated in the metal-cutting process. Also, the tool must have a specific geometry, with clearance angles designed so that the cutting edge can contact the work piece without the rest of the tool dragging on the work piece surface. The angle of the cutting face is also important, as is the flute width, number of flutes or teeth, and margin size. In order to have a long working life, all of the above must be optimized, plus the speeds and feeds at which the tool is run.

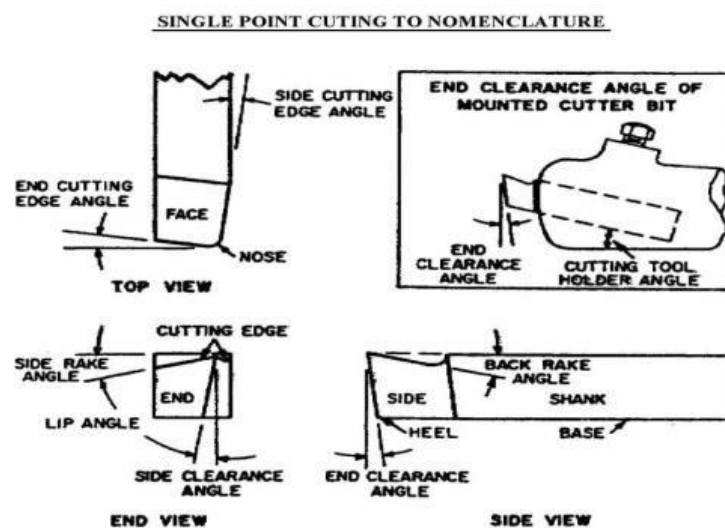

Fig.2 Showing parts & important angles cut on single point cutting tool

Single point cutting tool terms and definitions:

- (1) Shank: The shank is the main body of the tool.
- (2) Nose: The nose is the part of the cutter bit which is shaped to produce the cutting edges.
- (3) Face: The face of the cutter bit is the surface at the upper side of the cutting edge on which the chip strikes as it is separated from the workpiece.
- (4) Side: The side of the cutter bit is the near-vertical surface which, with the end of the bit, forms the profile of the bit. The side is the leading surface of the cutter bit used when cutting stock.
- (5) Base: The base is the bottom surface of the shank of the cutter bit.
- (6) End: The end of the cutter bit is the near-vertical surface which, with the side of the bit, forms the profile of the bit. The end is the trailing surface of the cutter bit when cutting.

(7) Heel: The heel is the portion of the cutter bit base immediately below & supporting the face.

Important angles of a Single Point Cutting Tool:

Angle	Details
Back Rake Angle	It is also called as Top Rake Angle. It is the slope given to the face or the surface of the tool. This slope is given from the nose along the length of the tool.
Side Rake Angle	It is the slope given to the face or top of the tool. This slope is given from the nose along the width of the tool. The rake angles help easy flow of chips
Relief Angle	These are the slopes ground downwards from the cutting edges. These are two clearance angles namely, side clearance angle and end clearance angle. This is given in a tool to avoid rubbing of the job on the tool.
Cutting Edge Angle	There are two cutting edge angles namely side cutting edge angle and end cutting edge angle. Side cutting edge angle is the angle, the side cutting edge makes with the axis of the tool. End cutting edge angle is the angle, the end cutting edge makes with the width of the tool.
Lip Angle	It is also called cutting angle. It is the angle between the face and end surface of the tool.
Nose Angle	It is the angle between the side cutting edge and end cutting edge.

Tool Signature

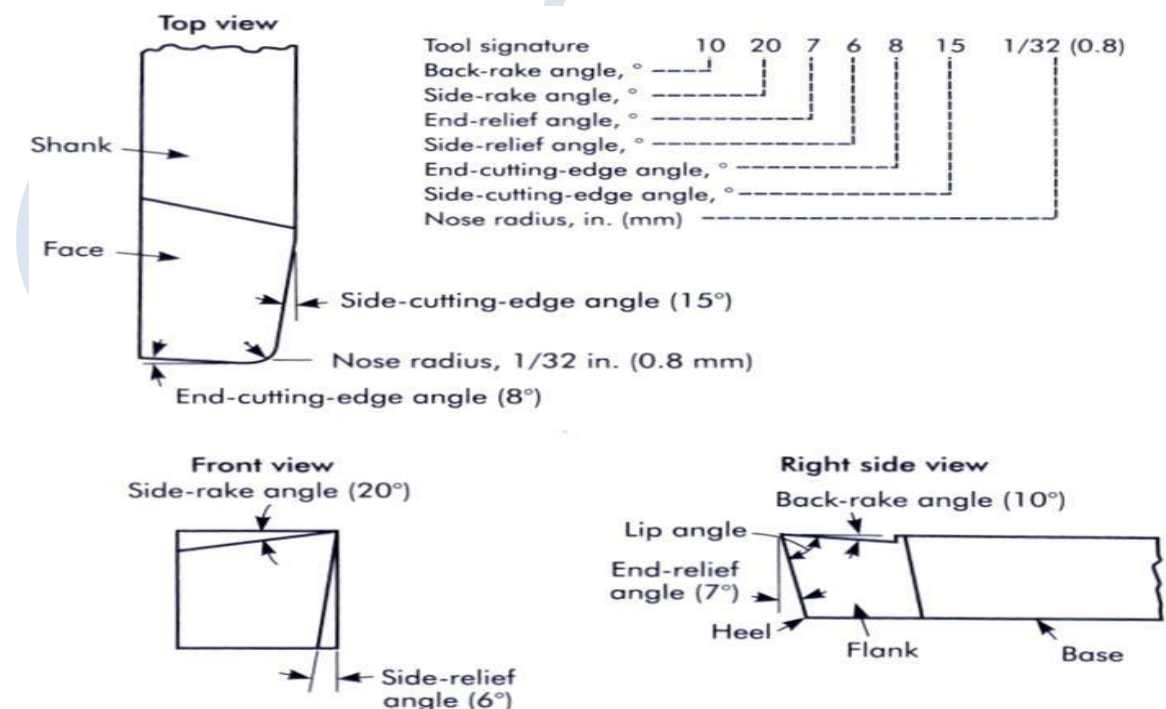

Fig.3 Tool Signature of Single Point Cutting Tool

Shapes of Tool Bits

The overall shape of the lathe tool bits can be rounded, squared, or another shape as long as the proper angles are included. Tool bits are identified by the function they perform, such as turning or facing. They can also be identified as roughing tools or finishing tools. Generally, a roughing tool has a radius ground onto the nose of the tool bit that is smaller than the radius for a finishing or general purpose tool bit. Experienced machinists have found the following shapes to be useful for different lathe operations. A right-hand turning tool bit is shaped to be fed from right to left.

The cutting edge is on the left side of the tool bit and the face slopes down away from the cutting edge. The left side and end of the tool bit are ground with sufficient clearance to permit the cutting edge to bear upon the work piece without the heel rubbing on the work. The right-hand turning tool bit turning tool bit is ideal for taking light roughing cuts as well as general all-around machining. The round-nose turning tool bit is very versatile and can be used to turn in either direction for roughing and finishing cuts. No side rake angle is ground into the top face when used to cut in either direction, but a small back rake angle may be needed for chip removal. The nose radius is usually ground in the shape of a half-circle with a diameter of about 1/32 inch. A left-hand turning tool bit is the opposite of the right-hand turning tool bit, designed to cut when fed from left to right. This tool bit is used mainly for machining close in to a right shoulder.

The right-hand facing tool bit is intended for facing on right hand side shoulders and the right end of a work piece. The cutting edge is on the left-hand side of the bit and the nose is ground very sharp for machining into a square corner. The direction of feed for this tool bit should be away from the center axis of the work, not going into the center axis. A left-hand facing tool bit is the opposite of the right-hand facing tool bit and is intend to machine and face the left sides of shoulders.

THIS WILL HELP YOU TO IDENTIFY A RIGHT-CUT AND A LEFT-CUT TOOL.

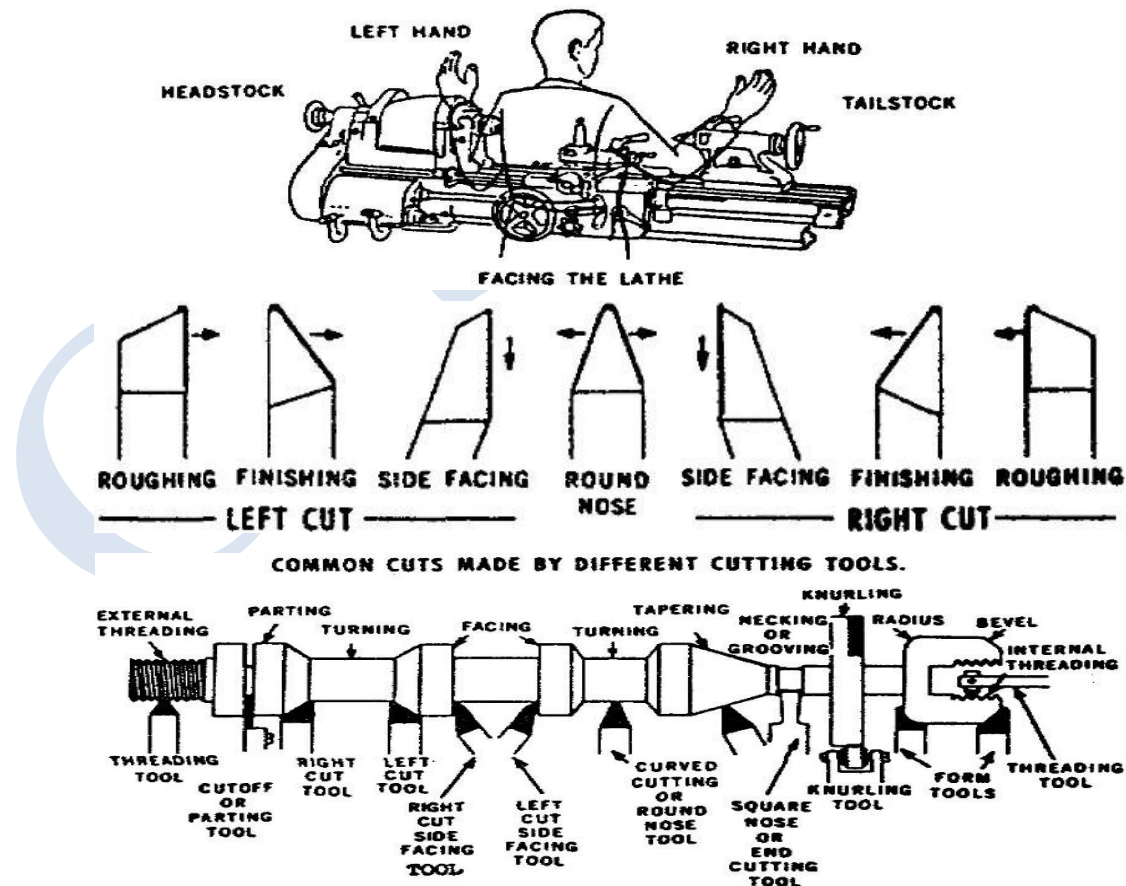

Fig. 3 Left – Hand & Right-hand Cutting tools

1.5.13 Multi Point Cutting Tool



Fig.4 Multipoint cutting tools

In multi point cutting tool the multiple edges are used to remove the material. Multi point cutting tools are used in Milling, drilling, reamers, slotting tool, wood ruff cutter, etc. most important thing to remember is the cutting tools must be made of a material harder than the material which is to be cut, and the tool must be able to withstand the heat generated in the metal-cutting process. Grinding tools are also multipoint tools. Each grain of abrasive functions as a microscopic single-point cutting edge

A multi-point cutting tool is regarded as a series of two or more cutting elements (chip producing elements) secured to a common body. The term such as face, flanks, and cutting edge, defined earlier for single-point tools, are applicable to multi-points tool as well. The commonly used multi-point cutting tools are drills, reamers, milling cutters, broaches, wood ruff cutter, reamers, etc.

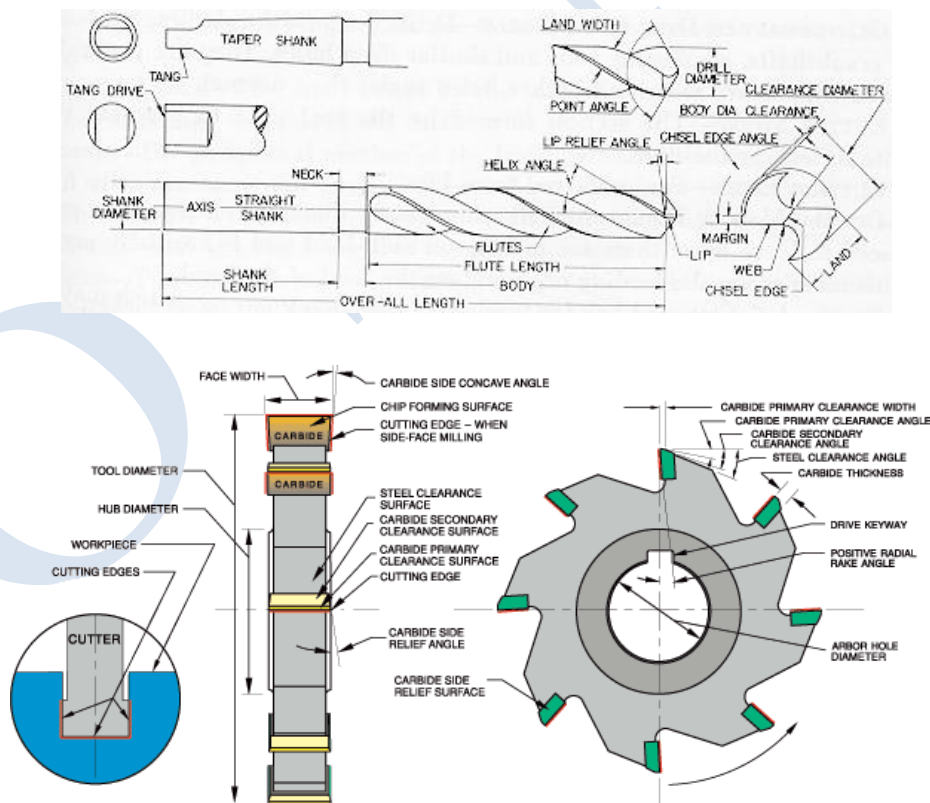

Fig.5 Showing parts & important angles of Multi Point Cutting Tools

1.6 ORTHOGONAL CUTTING (Two Dimensional Cutting)

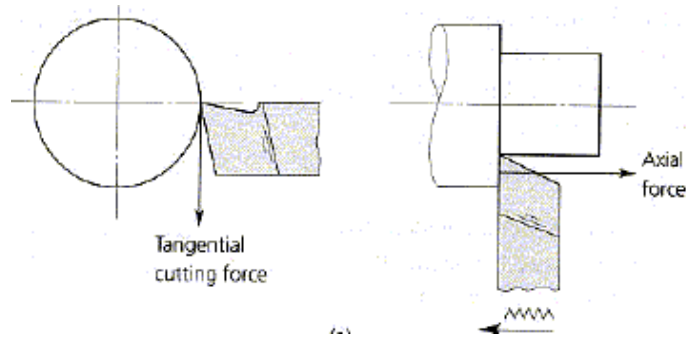

Fig.6 Orthogonal Cutting

1.7 OBLIQUE CUTTING (Three Dimensional Cutting)

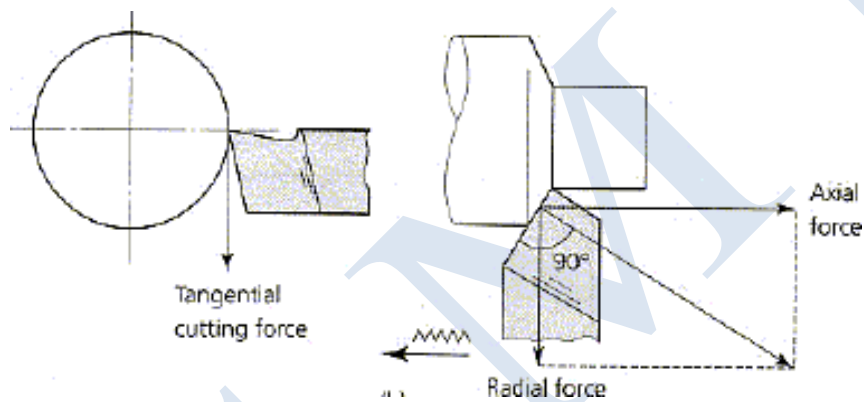

Fig.7 Oblique Cutting

Orthogonal Metal Cutting	Oblique Metal Cutting
Cutting edge of the tool is perpendicular to the direction of tool travel.	The cutting edge is inclined at an angle less than 90° to the direction of tool travel.
The direction of chip flow is perpendicular to the cutting edge.	The chip flows on the tool face making an angle.
The chip coils in a tight flat spiral	The chip flows sideways in a long curl.
For same feed and depth of cut the force which shears the metal acts on a smaller area. So the life of the tool is less.	The cutting force acts on larger area and so tool life is more.
Produces sharp corners.	Produces a chamfer at the end of the cut
Smaller length of cutting edge is in contact with the work.	For the same depth of cut greater length of cutting edge is in contact with the work.
Generally parting off in lathe, broaching and slotting operations are done in this method.	This method of cutting is used in almost all machining operations.

Experiment No- 7 (A)

IC ENGINE

Aim: -To Study the construction details & working principal of 2-Stroke / 4-Stroke Petrol Engine. Apparatus: - Models of 2-Stroke / 4-Stroke Engines.

Theory: - The working Principle of Engines.

Four Stroke (S.I) Engine.

In a four stroke engine, the cycles of operations is completed in 4 strokes of piston or 2 revolution of crank shaft. Each stroke consists of 180° & hence the fuel cycle consists of 720° of crank rotation. The 4- Strokes are:

Suction or Intake Stroke: - In starts at, when the piston is at top deadcentre & about to move downwards. The inlet valve is open at that time and exhaust valve is closed due to suction created by the motion of the piston towards the bottom dead centre, the charge containing air fuel mixture is drawn into the cylinder. When the piston reaches BDC the suction stroke ends and inlet valve is closed.

Compression Stroke: - The charge taken into the cylinder during suction stroke is compressed by return stroke of piston. During this stroke both the valves are closed. The mixture which fills the entire cylinder volume is now compressed into the clearance volume. At the end, the mixture is ignited with the help of electrode of spark plug. During the burning process the chemical energy of fuel is converted to heat energy. The pressure is increased in the end due to heat release.

Expansion Stroke: - The burnt gases escape out and the exhaust valve opens but inlet valve remaining closed the piston moves from BDC to TDC and sweeps the burnt gases out at almost atmospheric pressure. The exhaust valve gets closed at the end of this stroke. Thus, for one complete cycle of engine, there is only one power stroke while crank shaft makes 2 revolutions.

Exhaust Stroke: - During the upward motion of the piston, the exhaust valve is open and inlet valve is closed. The piston moves up in cylinder pushing out the burnt gases through the exhaust valve. As the piston reaches the TDC, again the inlet valve opens and fresh charge is taken in during next downward movement of the piston and the cycle is repeated.

2-Stroke (S.I) Engines. In a 2-Stroke engine, the filling process is accompanied by the charge compressed in a crank case or by a blower. The induction of compressed charge moves out the product of combustion through exhaust ports. Therefore, no piston stroke is required. For these 2-strokes one for compression of fresh charge and second for power stroke.

The charge conducted into the crank case through the spring loaded valve when the pressure in the crank case is reduced due to upward motion of piston during the compression stroke. After the compression & ignition expansion takes place in usual way.

During the expansion stroke the charge in crankcase is compressed. Near the end of the expansion stroke, the piston uncovers the exhaust ports and the cylinder pressure drops to atmosphere pressure as combustion produced leave the cylinder.

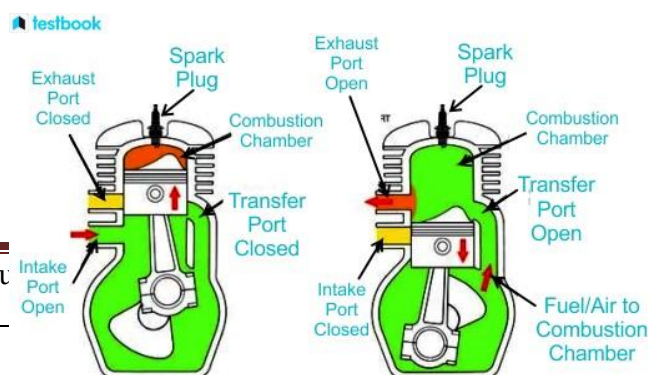

2 stroke petrol

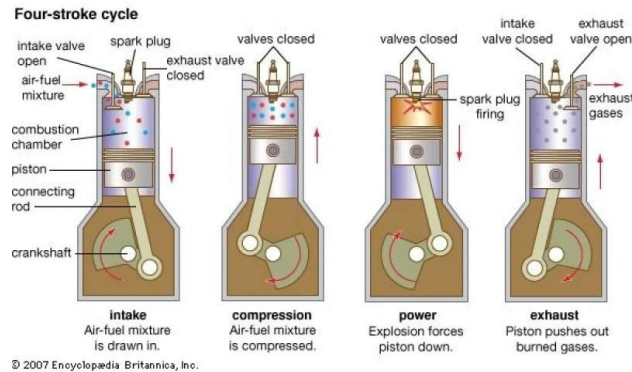

4 stroke petrol

Construction Details

Cylinder: - It is a cylindrical vessel or space in which the piston makes reciprocating produces. **Piston:** - It is a cylindrical component fitted into the cylinder forming the moving boundary of combustion system. It fits in cylinder perfectly.

Combustion Chamber: - It is the space enclosed in the upper part of cylinder, by the cylinder head & the piston top during combustion process.

Inlet Manifold: - The pipe which connects the intake system to the inlet valve of engine.

Exhaust Manifold: - The pipe which connects the exhaust system to the exhaust valve of engine. **Inlet /**

Exhaust Valves: - They are provided on the cylinder head to head to regulate the charge coming into or going out of the chamber.

Spark Plug: - It is used to initiate the combustion process in S.I engines.

Connected Rod: - It connects piston & the crank shaft.

Crank shaft: - It converts the reciprocating motion of the piston into useful rotary motion of output shaft.

Gudgeon pins: - It forms a link between connection rod and the piston.

Cam shaft: - It controls the opening & closing of the valves.

Cam: - They open the valves at the correct times.

Carburetor: - Used in S.I engine for atomizing & vaporizing and mixture it with air in varying proportion.

Experiment No- 7 (B)

IC ENGINE

Aim: - To study the constructional details & working principles involved in a 2-Stroke & 4-Stroke Diesel Engines.

Apparatus: - Model of 2-Stroke / 4-Stroke Diesel Engine.

Theory: -

Four Stroke (C.I.) Engine.

In four strokes C.I. Engine compression ratio is from 16 to 20. During suction stroke air is inducted. In C.I. engines high pressure. Fuel pump and injectors are provided to inject the fuel into combustion chamber and ignition chamber system is not necessary.

Construction Details

Suction: - During suction stroke, air is inducted through inlet valve.

Compression: - The air inducted is compressed into the clearance volume.

Expansion: - Fuel injection starts nearly at the end of the compression stroke. The rate of injection is such that the combustion maintains the pressure constant inspired of piston movement on its expansion stroke increasing the volume. After injection of fuel, the products of combustion chamber expand.

Exhaust: - The piston traveling from BQC to TDC pushes out the products of combustion out of cylinder.

Two Stroke (C.I.) Engine.

In two stroke engines, the cycle is completed in one revolution of the crankshaft. In 2-stroke engine, the filling process is accomplished by the charge compressed in crankcase or by a blower. The induction of compressed charge moves out of the exhaust ports. Therefore, no piston strokes are required for these 2 operations. Two strokes are sufficient to complete the cycle one for compressing the fresh charge and other for expansion or power stroke.

Compression: - The air or charge is inducted into the crankcase through the spring loaded inlet valve when the pressure in crankcase is reduced due to upward motion of piston.

Expansion: - During this, the charge in the crankcase is compressed. At the end the piston uncovers the exhaust ports and cylinder pressure drops to the atmospheric pressure. Further movement of piston opens the transfer ports, permitting the slightest compressed charge in the crankcase to enter the engine cylinder.

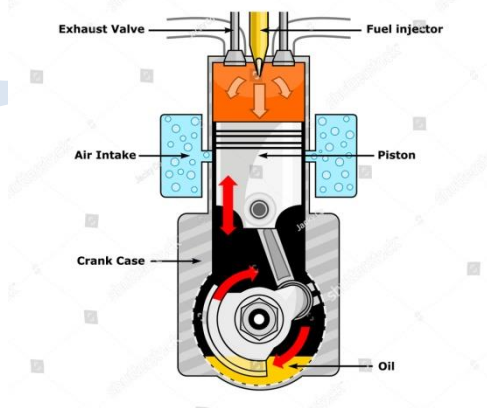

2 STROKE DIESEL

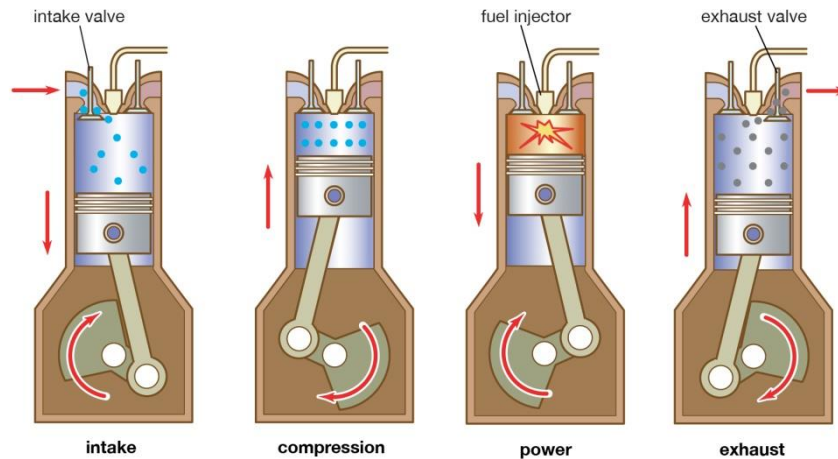

4 STROKE DIESEL ENGINE WORKING STROKE

Construction Details

Cylinder: - In it the piston makes a reciprocating process motion.

Piston: - It is a cylindrical component fitted into the cylinder forming the moving boundary of the combustion system. It fits into cylinder.

Combustion Chamber: - The space enclosed in the upper part of the cylinder, by the head and the piston top during the combustion process.

Inlet/ Outlet ports: - They are provided on the side of cylinder to regulate the charge coming in and out of cylinder.

Fuel Injector: - It injects the fuel in combustion chamber to initiate combustion process for power stroke.

Connecting Rod: - It interconnects crank shaft and the piston.

Fly Wheel: - The net torque imparted to the crankshaft during one complete cycle of operation of the engine fluctuates causing change in angular velocity of shaft. In order to achieve uniform torque an internal mass is attached to the output shaft & this is called as fly wheel.

Experiment No-8

SIMPLE SCREW JACK

AIM: To find the Mechanical Advantage, Velocity Ratio and Efficiency of Simple Screw-Jack.

APPARATUS REQUIRED:

Simple screw jack, Load to be lifted (W), Weights or Effort to be applied (P), Vernier caliper, Pan, Weight box.

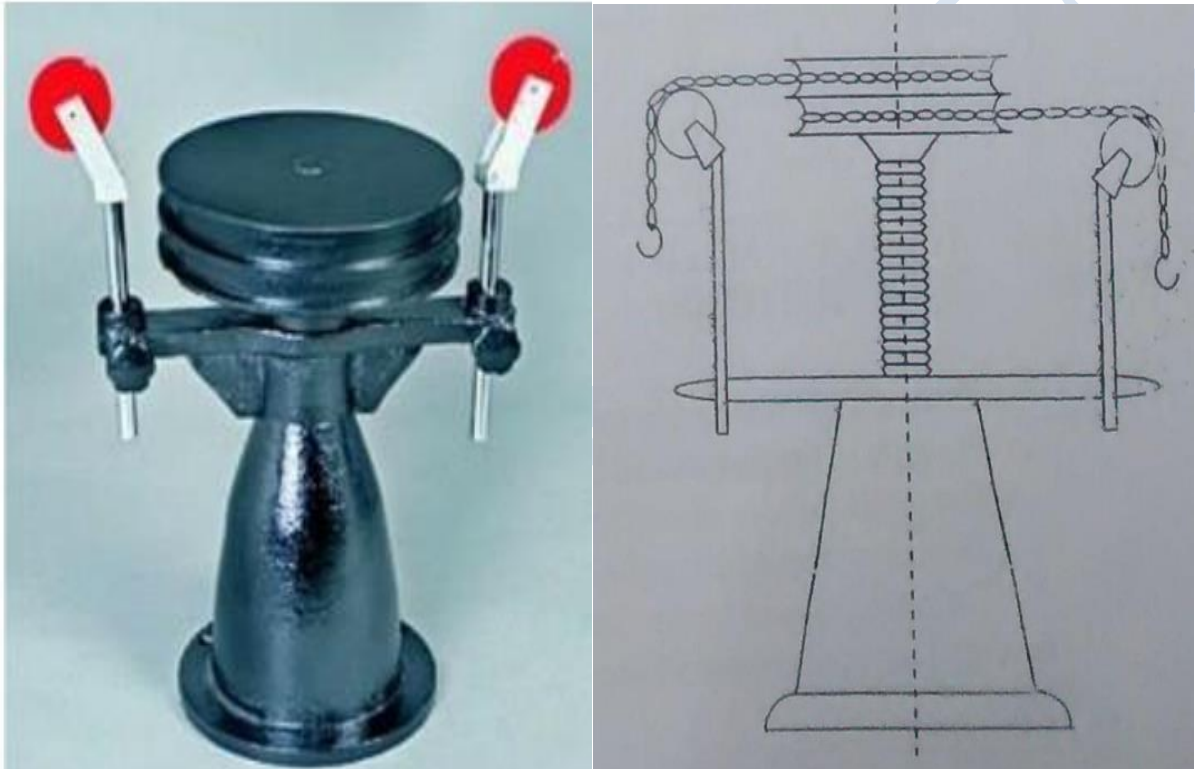

THEORY:

Screw Jack

- ✚ It is a device used for lifting heavy loads which are usually centrally loaded by applying smaller effort.
- ✚ It works on the principle of inclined plane. The device consists of a nut and screw. The load is carried by screw head. The body consisting of a nut is fixed and screw is rotated by means of a lever.
- ✚ The axial distance moved by the screw when it makes one complete revolution is known as the Lead of the screw. The distance between two consecutive threads is called Pitch of the screw.
- ✚ For single threaded screw Lead = Pitch, and for double threaded screw $L = 2p$

Mechanical Advantage

It is the ratio of weight lifted to effort applied. $M.A. = W/P$

Velocity Ratio

It is the ratio of distance moved by the effort (y) to the distance moved by the load (x). $V.R. = y/x$ In one complete revolution of the lever by effort P :

$$\text{Distance traveled by effort} = 2 \pi R$$

$$\text{And, distance traveled by the load} =$$

$$p \text{ Therefore, Velocity Ratio} = \frac{2 \pi R}{p}$$

$$\text{Mechanical efficiency}$$

$$= \frac{M.A.}{V.R.}$$

- i) **Parts of machine:** Simple screw jack fitted with nut
- ii) **Working of machine:** Screw jack fitted with a nut works on the principle similar to as that of an inclined plane. If screw is rotated by application of an effort applied at one end of pulley, load kept on load table will be lifted.
- iii) Take care, whether the string is properly wound on the circular disc or not.
- iv) Different loads are applied and corresponding efforts are recorded.
- v) To keep the friction constant, readings are taken at particular point.
- vi) Calculation for V.R. and efficiency is done.

PROCEDURE:

1. Note down the pitch ' p ' of the screw.
2. Measure the circumference of the flanged table with an inextensible thread and meter scale or measure the diameter of flanged table with the help of outside caliper.
3. Wrap the string around the circumference of the flanged table and pass it over one pulley. Similarly, wrap another string over the circumference of flanged table and take it over the second pulley. The free ends of both the strings be tied to two pans/hanger in which the weights are placed/hanged.
4. Place a load ' W ' on the top of the flanged table and start adding weights on to the pans gradually till the load starts lifting. P_1 and P_2 are the weights (effort) in the pans.
5. Calculate M.A, V.R and % Efficiency.
6. Repeat the above procedure by increasing the load on flanged table and note down the corresponding efforts applied.

OBSERVATIONS:

Let, Load Lifted = W

Effort Applied = P

Effort Wheel Diameter (D)

Diameter of the rope (d) =

Pitch of the screw (p) =

No. of teeth on the gear (N) =

Weight of the Pan (w) =

SR.NO	W(kg)	P(kg)	M.A=W/P	V.R=2πR/p	%η=M.A/V.R*100

Conclusion:

- i. Efficiency of machine is less than 50%, the machine is irreversible.
- ii. VR of machine remains constant.
- iii. Efficiency of machine increases with load in the beginning and then remains constant.
- iv. The graph line indicates a linear motion.
- v. As load on machine increases, the effort required to lift also increases

RESULT:

- i. V.R. of machine =
- ii. Efficiency of machine = $M.A. / V.R.$

Exp. No.9

Flywheel- Moment of inertia

Aim: To find the moment of inertia of a fly wheel.

Apparatus: The flywheel, weight hanger with slotted weights, stop clock, metre scale etc.

Theory: A flywheel is an inertial energy-storage device. It absorbs mechanical energy and serves as a reservoir, storing energy during the period when the supply of energy is more than the requirement and releases it during the period when the requirement of energy is more than the supply. The main function of a fly wheel is to smoothen out variations in the speed of a shaft caused by torque fluctuations. Many machines have load patterns that cause the torque to vary over the cycle. Internal combustion engines with one or two cylinders, piston compressors, punch presses, rock crushers etc. are the systems that have fly wheel.



A flywheel is a massive wheel fitted with a strong axle projecting on either side of it. The axle is mounted on ball bearings on two fixed supports as shown in fig.b. There is a small peg inserted loosely in a hole on the axle. One end of a string is looped on the peg and the other end carries a weight hanger. A pointer is arranged close to the rim of the flywheel. To do the experiment, the length of the string is adjusted such that when the descending mass just touches the floor, the peg must detach the

axle. Now a line is drawn on the rim with a chalk just below the pointer. The string is then attached to the peg and the wheel is rotated for a known number of times 'n' such that the string is wound over 'n' turns on the axle without overlapping. Now the mass m is at a height 'h' from the floor. The mass is then allowed to descend down. It exerts a torque on the axle of the flywheel. Due to this torque the flywheel rotates with an angular acceleration. Let ω be the angular velocity of the wheel when the peg just detaches the axle and W be the work done against friction per one rotation, then by law of conservation of energy,

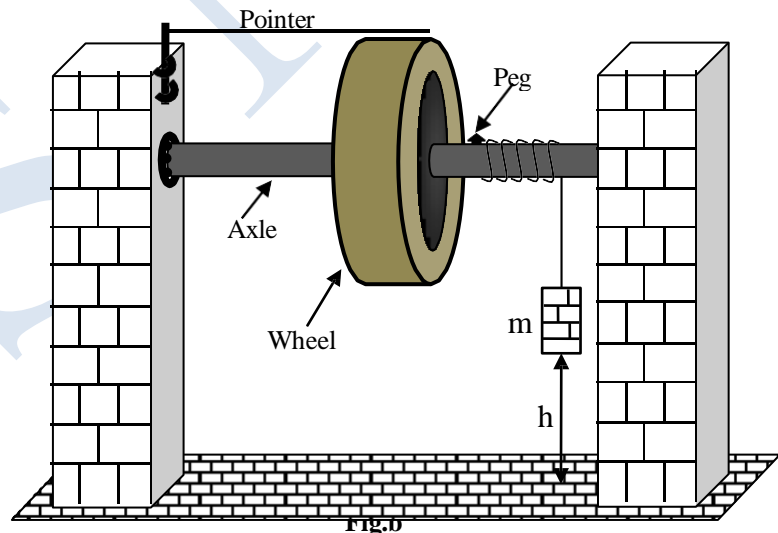

$$mgh = \frac{1}{2}I\omega^2 + \frac{1}{2}mv^2 + nW \quad (1)$$

Let N be the number of rotations made by the wheel before it stops. Since the kinetic energy of rotation of the flywheel is completely dissipated when it comes to rest, we can write,

$$NW = \frac{1}{2}I\omega^2$$

Or,
$$W = \frac{I\omega^2}{2N} \quad (2)$$

Using eqn.2 in eqn.1,

$$mgh = \frac{1}{2}I\omega^2 + \frac{1}{2}mv^2 + n \frac{I\omega^2}{2N} = \frac{1}{2}I\omega^2 \left(1 + \frac{n}{N}\right) + \frac{1}{2}mr^2\omega^2$$

$$\therefore I = \frac{Nm}{N+n} \left(\frac{2gh}{\omega^2} - r^2 \right) \quad (3)$$

where, 'r' is the radius of the axle. To determine 'ω' we assume that the angular retardation of the flywheel is uniform after the mass gets detached from the axle. Then,

$$\text{Average angular velocity} = \frac{\text{Total angular displacement}}{\text{Time taken}}$$

$$\frac{\omega + 0}{2} = \frac{2\pi N}{t}$$

$$\therefore \omega = \frac{4\pi N}{t} \quad (4)$$

Procedure: To start with the experiment one end of the string is looped on the peg and a suitable weight is placed in the weight hanger. The fly wheel is rotated 'n' times such that the string is wound over 'n' turns on the axle without overlapping. The flywheel is held stationary at this position. The height 'h' from the floor to the bottom of the weight hanger is measured. The flywheel is then released. The mass descends down and the flywheel rotates. Start a stop watch just when the peg detaches the axle. Count the number of rotations 'N' made by the wheel during the time interval between the peg gets detached from the axle and when the wheel comes to rest. The time interval 't' also is noted. The experiment is repeated for same 'n' and same mass 'm'. The average value of 'N' and 't' are determined. The moment of inertia 'I' is calculated using equations (3) and (4). The entire experiment is repeated for different values of 'n' and 'm' and the average value of I is calculated.

- Ensure that the length of the string is such that when the mass just touches the floor the peg gets detached from the axle.
- In certain wheels the peg is firmly attached to the axle. In such case, one end of the string is loosely looped around the peg such that when the mass just touches the floor the loop gets slipped off from the peg.
- 'm' is the sum of mass of weight hanger and the additional mass placed on it.

Observation and tabulation

To determine the radius of the axle using vernier calipers

Value of one main scale division (1 m s d) = cm

Number of divisions on the vernier scale, x =

Least count, L. C = $\frac{\text{Value of one main scale division}}{\text{Number of divisions on the vernier scale}} = \frac{1 \text{ m s d}}{x} = \dots\dots \text{ cm}$

Trial No.	M S R cm	V S R	D = M S R + V S R × L C cm	Mean diameter D cm

Diameter of the axle $D = \dots\dots \text{ cm} = \dots\dots \text{ m}$

Radius of the axle $r = \frac{D}{2} = \dots\dots \text{ m}$

Determination of moment of inertia

Mass suspended at one end of the string 'm' kg	Height from the floor to the bottom of weight hanger 'h' m	Number of windings of string on the axle 'n'	No. of rotations of the wheel after the detachment of the peg from the axle 'N'			Time interval in between the detachment of the peg and when the wheel comes to stop, 't' sec.			$\omega = \frac{4\pi N}{t}$	I kg.m ²
			1	2	Mean N	1	2	Mean t sec		

Result

Moment of inertia of the given flywheel, I = kg.m²

EXPERIMENT NO: 10

GOVERNOR

AIM: To Determine the centrifugal force of watt/Porter/hartnell Governor

THEORY:

The function of a governor is to regulate the mean speed of an engine, when there are variations in the load e.g. when the load on an engine increases, its speed decreases, therefore it becomes necessary to increase the supply of working fluid. If the load on the engine decreases, its speed increases and thus less working fluid is required. The governor automatically controls the supply of working fluid to the engine with the varying load conditions and keeps the mean speed within certain limits.

The governors may, broadly, be classified as:

1. Centrifugal governor
2. Inertia governor

The centrifugal governors may further be classified as follows:

1. pendulum type (watt governor)
2. Loaded type
 - i. Dead weight governor (Porter and Proell governor)
 - ii. Spring controlled governors (Hartnell governor, Hartung governor, Wilson Hartnell governor and Pickering governor)

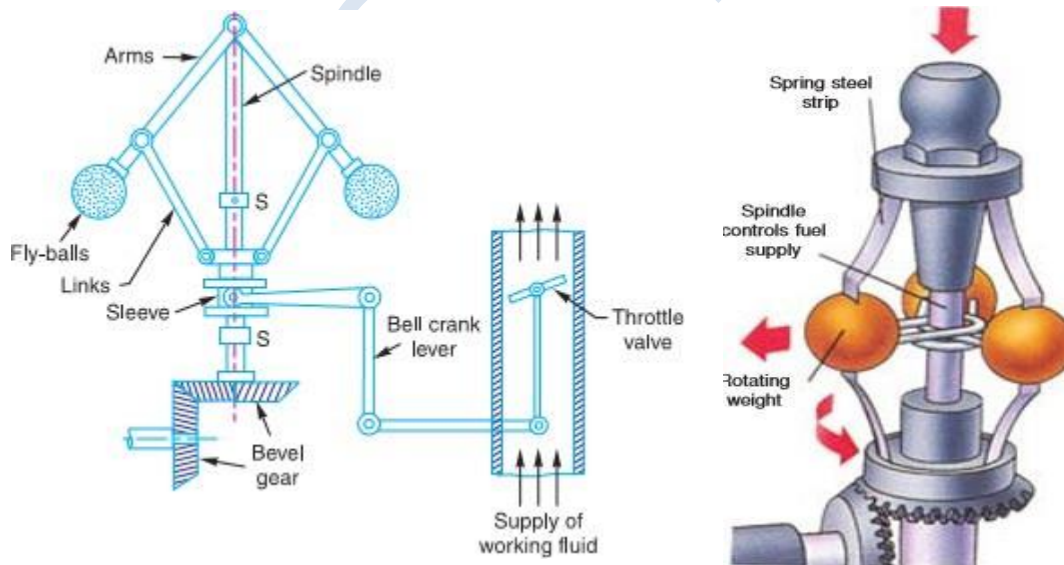

Centrifugal Governor

The centrifugal governors are based on the balancing of centrifugal force on the rotating balls by an equal and opposite radial force, known as the controlling force. It consists of two balls of equal mass, which are attached to the arms as shown in Fig1. These balls are known as governor balls or fly balls. The balls revolve with a spindle, which is driven by the engine through bevel gears. The upper ends of the arms are pivoted to the spindle, so that the balls may

rise up or fall down as they revolve about the vertical axis. The arms are connected by the links to a sleeve, which is keyed to the spindle. This sleeve revolves with the spindle; but can slide up and down. The balls and the sleeve rises when the spindle speed increases, and falls when the speed decreases. In order to limit the travel of the sleeve in upward and downward directions, two stops S, S are provided on the spindle. The sleeve is connected by a bell crank lever to a throttle valve. The supply of the working fluid decreases when the sleeve rises and increases when it falls

When the load on the engine increases, the engine and the governor speed decreases. This results in the decrease of centrifugal force on the balls. Hence the balls move inwards and the sleeve moves downwards. The downward movement of the sleeve operates a throttle valve at the other end of the bell crank lever to increase the supply of working fluid and thus the engine speed is increased. In this case, the extra power output is provided to balance the increased load. When the load on the engine decreases, the engine and the governor speed increases, which results in the increase of centrifugal force on the balls. Thus the balls move outwards and the sleeve rises upwards. This upward movement of the sleeve reduces the supply of the working fluid and hence the speed is decreased. In this case, the power output is reduced.

PROCEDURE:

Mount the required governor assembly over the spindle.

1. Tighten the necessary bolts.
2. Start the motor and gradually increase the speed.
3. The flyweight will fly outward due to which the sleeve will rise.
4. Note down the speed and sleeve rise or calculate by theoretical method.
5. Repeat the experiment at different speeds till the balls fly to maximum position.
6. Bring back the sleeve down by reducing the speed gradually and stop.

Specifications

Watt & Porter Governor

Weight of Balls= -----Kg

Initial height h_0 = ----- mm

Length of the link L = -----mm

Hartnell Governor

Initial height $h_0 = \text{----- mm}$

Length of the link $L = \text{-----mm}$

TABULATION

Sl.No	Sleeve lift in cm	Rpm N	Radius of rotation	Centrifugal force F

$x =$ raise of sleeve in cm
 $h_0 =$ initial height
 $w =$ weight of balls
 $L =$ length of the link

$$\omega = 2\pi N / 60$$

$N =$ Speed in rpm

Initial radius of rotation = r_1

CALCULATION

- Height of balls where link centre lines intersect $h = m$

$$h = \frac{h_0 + X}{2}$$

- Initial radius of rotation = r_1

$$r_1 = \sqrt{L^2 - h^2}$$

- $r = r_1 + 0.16$

- Angular speed

$$\omega = \frac{2\pi N}{60}$$

- Centrifugal force

$$F = \frac{W}{g} \times \omega^2 \times r$$

PORTER GOVERNOR (WITH WEIGHT)

The Porter governor is a modification of a Watt's governor, with central load attached to the sleeve as shown in Fig 2. The load moves up and down the central spindle. This additional downward force increases the speed of revolution required to enable the balls to rise to any predetermined level.

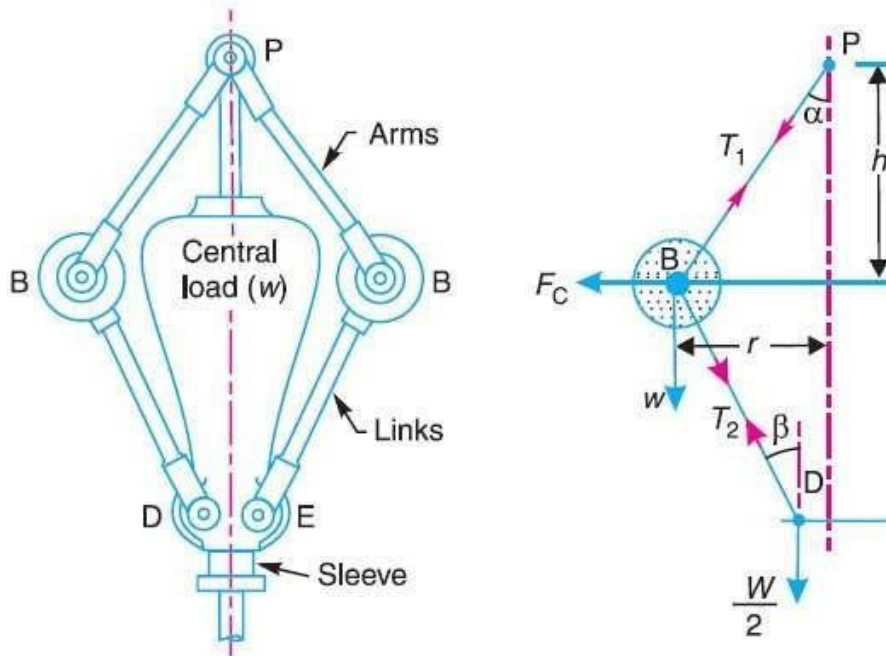

Porter governor.
Fig 2

TABULATION

SI No	LIFT X in mm	Speed in Rpm	h in m	r ₁ in mm	r in mm	ω in rad/sec	Centrifugal force in Kgf

WATT GOVERNOR (WITHOUT WEIGHT)

The simplest form of a centrifugal governor is watt governor (Fig3). It is basically a conical pendulum with links attached to a sleeve of negligible mass. The arms of the governor may be connected to the spindle in the following three ways:

1. The pivot P may be on the spindle axis.
2. The pivot P may be offset from spindle axis and arms when produced intersect at O.
3. The pivot P may be offset but the arms cross the axis at O.

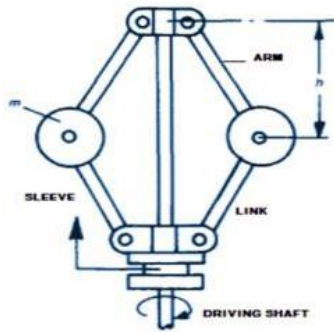

WATT GOVERNOR

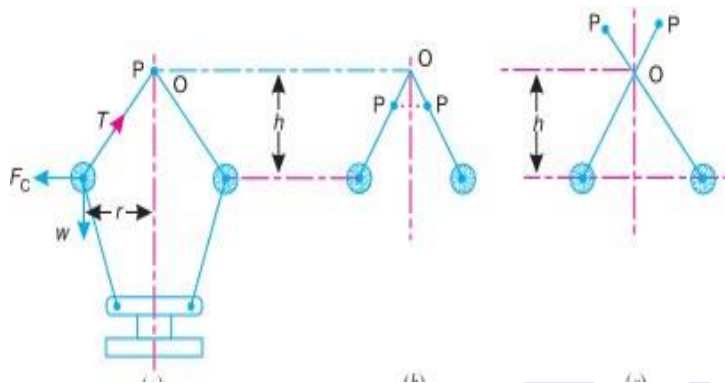

Fig 3

TABULATION

No	LIFT X in mm	Speed in Rpm	H in m	r_1 in mm	r in mm	ϕ in rad/sec	Centrifugal force in Kgf

HARTNELL GOVERNOR

A Hartnell governor is a spring loaded governor as shown in Fig 5. It consists of two bell crank levers pivoted at the points O, O to the frame. The frame is attached to the governor spindle and therefore rotates with it. Each lever carries a ball at the end of the vertical arm OB and a roller at the end of the horizontal arm OR. A helical spring in compression provides equal downward forces on the two rollers through a collar on the sleeve. The spring force may be adjusted by screwing a nut up or down on the sleeve

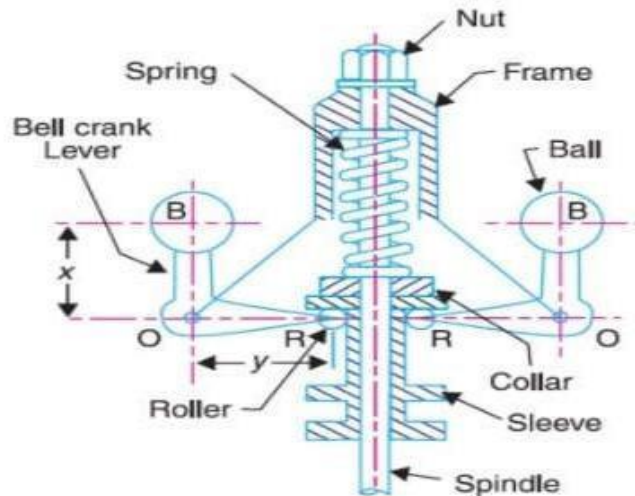

TABULATION

Sl No	Lift X In m	Speed In Rpm	h In m	r1 In m	ω In Rad/Sec	Centrifugal Force(Kgf)

PRECAUTIONS:

1. DO NOT KEEP THE MAINS ON when trial is complete increase the speed gradually.
2. Take the sleeve displacement reading when the pointer remains steady.
3. See that at higher speed the load on sleeve does not hit the upper sleeve of the governor.
4. while closing the test bring the dimmer to zero position and then switch OFF

VIVA –QUESTIONS:

1. What is the function of a governor?
2. How does it differ from that of a flywheel?
3. State the different types of governors.
4. What is the difference between centrifugal and inertia type governors ?
5. Explain the term height of the governor.
6. What are the limitations of a Watt governor?
7. What is the stability of a governor?
8. Define the Sensitiveness of governor.
9. Which of the governor is used to drive a gramophone?
10. The power of a governor is equal to

RESULT:

CONCLUSION:

OSSIME