



ORISSA SCHOOL OF MINING ENGINEERING
DEPT. OF DRILLING ENGINEERING

LECTURE NOTES
ON
FLUID MECHANICS & HYDRAULIC MACHINES
6th Semester

Prepared by

Mr. Tapas Ranjan Sutar

Lecturer, Department of Drilling Engineering

OSME, Keonjhar

FLUID MECHANICS

SL. No.	CONTENTS	PAGE NO.
1	Properties of Fluid	1-08
2	Fluid Pressure and It's Measurements	08-16
3	Hydrostatics	16-23
4	Kinematics of flow	23-46
5	Orifices, Notches and Weirs	46-54
6	Flow Through pipes	54-59

FLUID MECHANICS

- It is the branch of engineering science which deals with the behavior of the fluid at rest as well as in motion.
- The study of fluid at rest is called fluid statics.
- The study of fluid in motion where pressure forces are not considered is called fluid Kinematics.
- The study of fluid in motion where the pressure forces are considered is called fluid Dynamics.

Fluid

- It is the substance that continuously deforms under the applied shear stress.
- A substance that has no fixed shape and yields easily to external pressure.
- Fluid, which is state of matter such as liquid or gas can flow easily and conform to the shape of their container.
- Fluid having particles that can easily move and change their relative motion.

Fluids are broadly classified into two types.

- Ideal fluids
- Real fluids

Ideal fluid:

An ideal fluid is one which has no viscosity and surface tension and is incompressible actually no ideal fluid exists.

Real fluids:

A real fluid is one which has viscosity, surface tension and compressibility in addition to the density.

PROPERTIES OF FLUID

1. Density or mass density or specific density

Mass density: density of a fluid is defined as the ratio of the mass of a fluid to its volume simply it is the mass per unit volume.

It is denoted by the symbol ρ and unit of mass density is kg/m^3 in S.I. system.

$$\text{Mathematically, } \rho = \frac{\text{mass of the fluid}}{\text{volume of the fluid}}$$

Density of water is 1000 kg/m^3 (Standard volume)

2. Specific weight or weight density

Specific weight of a fluid is the ratio between the weights of a fluid to its volume.

It is denoted by 'w'

$$\text{Mathematically, } w = \frac{\text{weight of a fluid}}{\text{volume of a fluid}} \text{ N/m}^3$$

$$= \frac{\text{mass} \times \text{acceleration due to gravity}}{\text{volume of a fluid}} = \rho \times g$$

Value of specific weight for water is $1000 \times 9.81 = 9810 \text{ N/m}^3$

3. Specific volume

Specific volume of a fluid is defined as the volume of a fluid occupied by a unit mass.

$$\begin{aligned} \text{Specific volume} &= \frac{\text{volume of fluid}}{\text{mass of fluid}} \text{ m}^3/\text{kg} \\ &= \frac{1}{\frac{\text{mass of fluid}}{\text{volume of fluid}}} \\ &= \frac{1}{\rho} \end{aligned}$$

The specific volume is the reciprocal of mass density is expressed as m^3/kg , is commonly applied to gases.

4. Specific gravity

It is defined as the ratio of the weight density or density of fluid to the weight density or density of standard fluid.

- For liquid standard fluid is taken as water and for gases standard fluid is

taken as gases.

- Specific gravity is also called as relative density.

Mathematically, $S = \frac{\text{density or specific weight of gravity of fluid}}{\text{density or specific weight of given standard fluid}}$

$S_{\text{liquid}} = \frac{\text{density or specific weight of gas}}{\text{density or specific weight of given liquid}}$

$S_{\text{gas}} = \frac{\text{density or specific weight of given gas}}{\text{density or specific weight of air}}$

From above formula,

Density or specific weight of liquid = $S_{\text{liquid}} \times$ specific weight of water

Density or specific weight of gas = $S_{\text{gas}} \times$ density or specific weight of air

Viscosity

It is defined as the property of liquid which offers resistance to the movement of one layer of fluid over another adjacent layer of that fluid.

- When two layers of a fluid at a distance 'dy' apart move one over the other at a different velocity 'u' and u + du.
- The velocity together with relative velocity causes a shear stress acting between the fluid layers.
- The top layer causes a shear stress on the adjacent lower layer while the lower layer causes a shear stress on the adjacent top layer.
- The shear stress (τ) caused is proportional to the rate of change of velocity with respect to y.

Mathematically,

$$\tau \propto \frac{du}{dy}$$

$$\tau = \mu \frac{du}{dy}$$

$$\mu = \frac{\tau}{\frac{du}{dy}}$$

where, μ is the constant proportionality and it is known as co-efficient of dynamic viscosity or simple viscosity.

$\frac{du}{dy}$ Represents the rate of shear stress or velocity gradient.

Viscosity is also defined as the shear stress required to produce unit rate of shear stress.

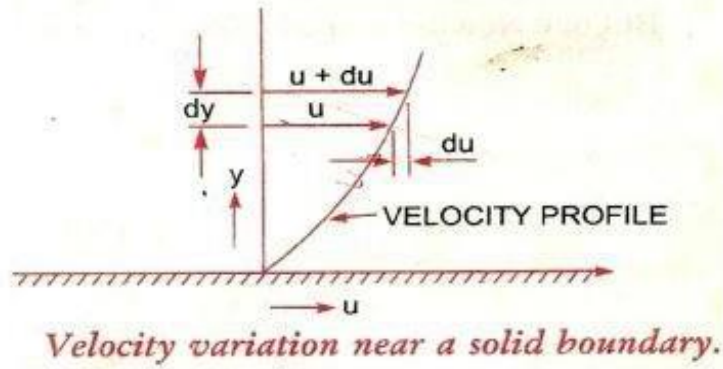

Unit of Viscosity

$$\mu = \frac{\text{shear stress}}{\frac{\text{change in velocity}}{\text{change in distance}}}$$

$$\begin{aligned} & \frac{\frac{\text{force}}{\text{area}}}{\frac{\text{length}}{\text{time}}} = \frac{\text{force}}{\text{area}} \times \frac{\text{time}}{\text{length}} \\ & = \frac{\text{force} \times \text{time}}{\text{area} \times \text{length}} \end{aligned}$$

$$= \frac{\text{force} \times \text{time}}{\text{area}}$$

Unit of viscosity in S.I system - $\frac{Ns}{m^2}$

in C.G.S - $\frac{\text{Dyne s}}{cm^2}$

in M.K.S. - $\frac{kgfs}{m^2}$

- The unit of viscosity in CGS system is also called poise.

$$\frac{\text{Dyne s}}{\text{cm}^2} = 1 \text{ Poise}$$

$$1 \frac{\text{Ns}}{\text{m}^2} = 10 \text{ poise}$$

$$1 \text{ Centipoise} = \frac{1}{100} \text{ poise}$$

Kinematic Viscosity

It is defined as the ration between the dynamic viscosity and density of fluid.

- It is denoted by symbol 'v'.

$$\text{Mathematically, } v = \frac{\text{dynamic viscosity}}{\text{density of fluid}} = \frac{\mu}{\rho}$$

Unit of Kinematic viscosity:

$$V = \frac{\frac{\text{force} \times \text{time}}{\text{area}}}{\frac{\text{mass}}{\text{volume}}}$$

$$= \frac{\frac{\text{mass} \times \frac{\text{length}}{\text{time}^2} \times \text{time}}{\text{length}^2}}{\frac{\text{mass}}{\text{length}^3}} = \frac{(\text{length})^2}{\text{time}} = \frac{\text{m}^2}{\text{sec}}$$

- In M.K.S. and S.I., the unit of Kinematic viscosity is $\frac{\text{m}^2}{\text{sec}}$
- In C.G.S. unit, the unit of Kinematic viscosity is $\frac{\text{cm}^2}{\text{sec}}$

The unit of Kinematic viscosity in C.G.S. is called stoke.

$$1 \text{ stoke} = \frac{\text{cm}^2}{\text{sec}} = 10^{-4} \frac{\text{m}^2}{\text{sec}}$$

$$1 \text{ centistoke} = \frac{1}{100} \text{ stoke.}$$

Newton's Law of Viscosity

It states that shear stress (τ) on a fluid element layer is directly proportional

to rate of shear strain. The constant of proportionality is called co-efficient of viscosity. τ

$$= \mu \frac{du}{dy}$$

Variation of viscosity with temperature-

Temperature affects the viscosity. The viscosity of fluids decreases with the increase of temperature.

Types of fluid:

- (i) **Ideal fluid:** a fluid which is incompressible and having no viscosity is known as an ideal fluid.
It is imaginary fluids as all the fluids exist have some viscosity.
- (ii) **Real fluid:** Fluids, which possess viscosity is known as real fluid.
All the fluids in actual practice are real fluids.

Real fluids are again sub divided into two types:-

Newtonian fluid: a real fluid in which the shear stress is directly proportional to the rate of shear strain is known as Newtonian fluid.

Non-Newtonian fluid: the fluid in which the shear stress as not proportional to the rate of shear strain is known as non-Newtonian fluid.

Surface Tension: It is defined as the tensile force action on the surface of a liquid in contact with a gas or on the surface between two immiscible liquids such that the contact surface behaves like a membrane under tension.

It is denoted by the symbol sigma (σ).

Units:

In M.K.S. unit= $\frac{Kgf}{m}$

In CGS unit= $\frac{dyne}{cm}$

In SI unit= $\frac{N}{m}$

Capillarity: It is defined as a phenomenon of rise or fall of a liquid surface in a small tube relative to the adjacent general level of liquid when the tube is held vertical in liquid.

- The rise of liquid surface is known as Capillary rise while he fall of liquid surface is known as capillary depression or capillary fall.

- It is expressed in terms of cm or mm.

Mathematically, Capillarity (h) = $\frac{4\sigma}{\rho g d}$

Where, σ = surface tension acting on liquid

ρ = density of the liquid

g = acceleration due to gravity

d = diameter of tube

Problem: - 1

Calculate the specific weight, density and specific gravity of one litre of a liquid which weighs 7N.

Solution. Given :

$$\text{Volume} = 1 \text{ litre} = \frac{1}{1000} \text{ m}^3 \quad \left(\because 1 \text{ litre} = \frac{1}{1000} \text{ m}^3 \text{ or } 1 \text{ litre} = 1000 \text{ cm}^3 \right)$$

$$\text{Weight} = 7 \text{ N}$$

$$(i) \text{ Specific weight } (w) = \frac{\text{Weight}}{\text{Volume}} = \frac{7 \text{ N}}{\left(\frac{1}{1000} \right) \text{ m}^3} = 7000 \text{ N/m}^3. \text{ Ans.}$$

$$(ii) \text{ Density } (\rho) = \frac{w}{g} = \frac{7000}{9.81} \text{ kg/m}^3 = 713.5 \text{ kg/m}^3. \text{ Ans.}$$

$$(iii) \text{ Specific gravity} = \frac{\text{Density of liquid}}{\text{Density of water}} = \frac{713.5}{1000} \quad \{ \because \text{Density of water} = 1000 \text{ kg/m}^3 \}$$
$$= 0.7135. \text{ Ans.}$$

Problem: - 2

Calculate the density, specific weight and specific gravity of one litre of petrol of specific gravity = 0.7

Solution. Given : Volume = 1 litre = $1 \times 1000 \text{ cm}^3 = \frac{1000}{10^6} \text{ m}^3 = 0.001 \text{ m}^3$

Sp. gravity $S = 0.7$

(i) Density (ρ)

Using equation (1.1.A),

Density (ρ) $= S \times 1000 \text{ kg/m}^3 = 0.7 \times 1000 = \mathbf{700 \text{ kg/m}^3}$. Ans.

(ii) Specific weight (w)

Using equation (1.1), $w = \rho \times g = 700 \times 9.81 \text{ N/m}^3 = \mathbf{6867 \text{ N/m}^3}$. Ans.

(iii) Weight (W)

We know that specific weight $= \frac{\text{Weight}}{\text{Volume}}$

$$w = \frac{W}{0.001} \text{ or } 6867 = \frac{W}{0.001}$$

$\therefore W = 6867 \times 0.001 = \mathbf{6.867 \text{ N}}$. Ans.

FLUID PRESSURE & ITS MEASUREMENTS

Fluid pressure

- When a fluid is contained in a vessel/container it exerts force at all points on the sides and bottom of the container.
- The force acting per unit area of that container is called pressure.
- Simply, pressure may be defined as force per unit area.
- Pressure at a point is called intensity of pressure.

Mathematically, $P = \frac{F}{A}$

Where, $F =$ force acting

$A =$ area on which the force acts.

The pressure of a fluid on a surface will always act normal to the surface.

Pressure Head

A liquid is subjected to pressure due to its own weight, this pressure increases as the depth of liquid increases.

Consider a vessel containing liquid, this liquid will exert pressure on all sides and bottom of the container.

Now, let a cylinder be made to stand in liquid,

Let, h = height of the liquid in cylinder

A = area of the base of cylinder

W = specific weight of liquid = ρg

P = intensity of pressure

Total force or pressure force = weight of the liquid in cylinder.

$$P.A. = w.v$$

$$P.A. = w.Ah$$

$$P.A. = \rho gAh$$

$$P = \rho gh$$

A liquid pressure by the height of the free surface which would cause the pressure.

The height of the free surface above any point is known as static pressure head.

$$\text{Pressure head}(h) = \frac{P}{\rho g} \text{ or } \frac{P}{W}$$

Units- m or mm.

Classification of Pressure

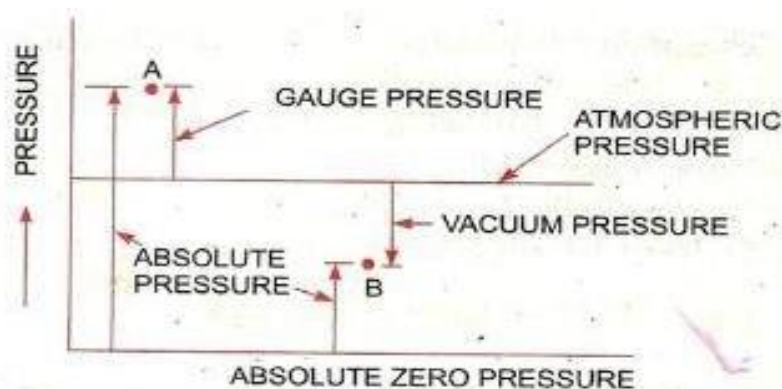

The pressure on a fluid is measured into different system

- In one system it is measured above the absolute zero or complete vacuum and it is called as absolute pressure.
- In other system pressure is measured above the atmospheric pressure it is called gauge pressure.

Atmospheric Pressure

- The atmospheric air exerts a normal pressure upon all surfaces with which it is in contact and it is known as atmospheric pressure.
- The atmospheric pressure is also known as barometric pressure.
- The atmospheric pressure at sea level is called as standard atmospheric pressure.

Absolute Pressure: It is defined as the pressure which is measured with reference to absolute vacuum pressure.

Gauge Pressure: It is the pressure measured with the help of pressure measuring instrument in which atmospheric pressure is taken as datum.

- The atmospheric pressure on the scale is marked as zero.

Vacuum Pressure: It is defined as the pressure below the atmospheric pressure.

According to the graph the following relation can be obtained:

$$P_{\text{absolute}} = P_{\text{atm}} + P_{\text{gauge}}$$

$$P_{\text{vacuum}} = P_{\text{atm}} - P_{\text{abs}}$$

- The atmospheric pressure at sea level at 1500°C is $101.3 \frac{kN}{m^2}$ or $10.13 \frac{N}{m^2}$ in SI unit.

- In case of MKS unit it is equal to $1.033 \frac{kgf}{m^2}$

According to pressure head of actual practice fluid pressure are divided into two types:

Low pressure: when pressure head is low in pipe cross section.

High pressure: when pressure head is high in pipe cross section.

Pressure Measuring Devices

Basically, manometers and pressure gauge are used for measuring the fluid pressure.

Manometers are used for measuring low pressure of pipe while pressure gauge is used for measuring the high pressure of fluid.

Manometer: manometers are defined as the device used for measuring the pressure a point in a fluid by balancing the column of fluid by the same or another column of fluid.

Types of manometers:

- (i) Piezometer
- (ii) U-tube manometer
- (iii) Single column manometer

Simple Manometer: A simple manometer is one which consists of a glass tube whose one end is connected to a point where pressure is to be measured and the other end remains open to the atmosphere.

(i) Piezometer

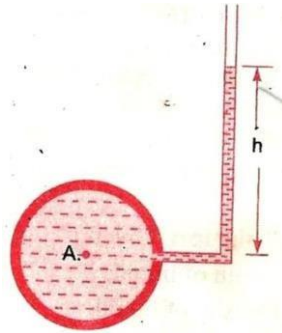

A piezometer is the simplest form of manometer which measure moderate pressure or low pressure.

The pressure at any point in the liquid is indicated by the height of the liquid of the liquid in the tube above that point, which can be reached on the scale attached to it.

(ii) U-tube manometer

It consists of a glass tube bent in U-shape, one end of which is connected to the pipe where pressure is to be determined and other end is open to atmosphere.

The tube generally contains mercury or any other liquid whose specific gravity is greater than the whose pressure is to be determined.

Let, h_1 = height of the liquid above datum line.

h_2 = height of heavy liquid above datum line.

ρ_1 = density of lighter liquid

ρ_2 = density of heavy liquid.

Let, 'A' be the point at which pressure is to be determined.

The pressure in the left limb and right limb above the datum line X-X are equal.

Pressure above, X-X in the left limb = pressure above X-X in right limb.

P = pressure at point A.

$$\Rightarrow \rho_1 g h_1 = \rho_2 g h_2$$

$$\Rightarrow P = \rho_2 g h_2 - \rho_1 g h_1$$

The negative pressure or vacuum pressure.

Pressure above X-X in the left limb = Pressure above X-X in the right limb.

$$\Rightarrow P + \rho_2 g h_2 + \rho_1 g h_1 = 0$$

$$\Rightarrow P = -(\rho_1 g h_1 + \rho_2 g h_2)$$

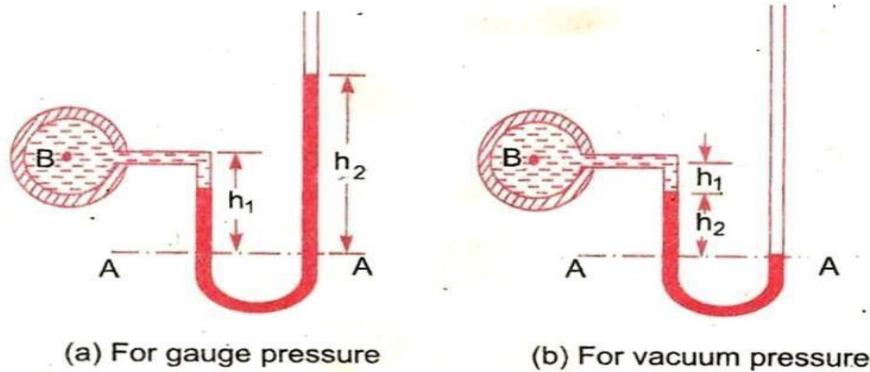

Differential Manometer

Differential manometers are the devices which are used for measuring the difference of pressure between two points in a pipe or in two different pipes.

Most common types of differential manometers are-

- (i) U-tube differential manometers.
- (ii) Inverted U-tube differential manometers.

U-tube differential manometers

Let the two points A and B are at different levels and also contains liquids of different specific gravity. These points are connected to the U-tube differential manometer.

Let the pressure at A and B are P_A and P_B respectively

h = difference of mercury level in the U-tube.

y = distance of the centre of B from the mercury level in the right limb.

x = distance of the center of A from the mercury level in the left limb.

ρ_1 = density of liquid at A.

ρ_2 = density of liquid at B.

ρ_g = density of heavy liquid or mercury.

Taking datum line X-X.

$$\text{So, pressure above X-X in left limb} = \rho_1 g(h+x) + P_A \dots \dots \dots (1)$$

$$\text{Pressure above X-X in right limb} = \rho_2 gh + \rho_g gy + P_B \dots \dots \dots (2)$$

Equating the two-pressure equation (1) & (2)

$$\begin{aligned} \Rightarrow \rho_1 g(h+x) + P_A &= \rho_2 gh + \rho_g gy + P_B \\ \Rightarrow P_A - P_B &= \rho_2 gh + \rho_g gy - \rho_1 g(h+x) \\ \Rightarrow P_A - P_B &= \rho_2 gh + \rho_3 gy - \rho_1 g(h+x) \\ \Rightarrow P_A - P_B &= \rho_2 gh + \rho_g gy - \rho_1 gh - \rho_1 gx \\ \Rightarrow P_A - P_B &= \rho_2 gh - \rho_1 gh + \rho_g gy - \rho_1 gx \\ \Rightarrow P_A - P_B &= gh(\rho_g - \rho_1) + \rho_2 gy - \rho_1 gx \end{aligned}$$

In next figure, pipes A and B are at the same level and contains the same liquid of density ρ_1 .

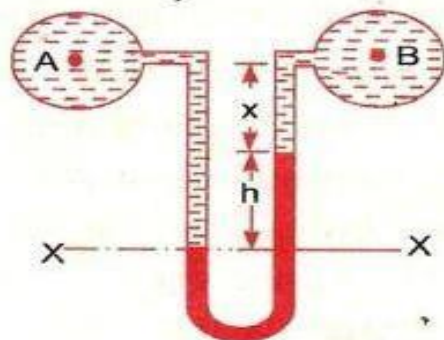

$$\text{Pressure above datum X-X in the left limb} = P_A + \rho_1 g(h+x) \dots \dots \dots (1)$$

$$\text{Pressure above datum X-X in the right limb} = P_B + \rho_1 gx + \rho_g gh \dots \dots \dots (2)$$

Equating above two equations, we get:

$$P_A + \rho_1 g(h+x) = P_B + \rho_1 gx + \rho_g gh$$

$$P_A - P_B = \rho_1 gx + \rho_g gh - \rho_1 g(h+x)$$

$$P_A - P_B = \rho_1 gx + \rho_g gh - \rho_1 gh - \rho_1 gx$$

$$P_A - P_B = gh(\rho_g - \rho_1)$$

Inverted U-tube differential manometer

It consist of an inverted U-tube containing a light liquid. The two ends of the tube are connected to the points whose difference of pressure is to be measured.

It is used for measuring difference of low pressure.

In figure U-tube differential manometer aconnected to the two tubes A and B.

Let,

h_1 = height of liquid in the left limb below the datum line X-X.

h_2 = height of liquid in right limb.

h = difference of height of light liquid.

ρ_1 = density of liquid at A.

ρ_2 = density of liquid at B.

ρ_g = density of mercury.

P_A = pressure at A.

P_B = pressure at B.

Pressure of pipe A below datum X-X at left limb= $P_A - \rho_1 g h_1$ (1)

Pressure of pipe B below datum X-X at right limb= $P_B - \rho_g g h - \rho_2 g h_2$ (2)

Equating above equation, we get:

$$P_A - \rho_1 g h_1 = P_B - \rho_g g h - \rho_2 g h_2$$

$$\Rightarrow P_A - P_B = - \rho_g g h - \rho_2 g h_2 + \rho_1 g h_1$$

$$\Rightarrow P_A - P_B = - \rho_1 g h_1 - \rho_g g h + \rho_2 g h_2$$

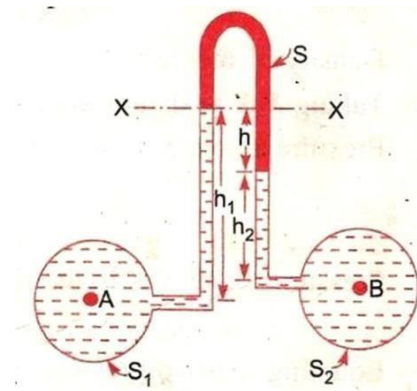

Mechanical Gauge

Whenever a very high fluid pressure is to be measured a mechanical gauge is best sited for the purpose.

Mechanical gauge is also used for the measurement of pressure in boilers, turbines or in other pipes where manometres cannot be conveniently used.

There are three types of gauge used for measuring high pressure-

1. Bourdon's Tube pressure gauge
2. Diaphragm pressure gauge
3. Dead weight type pressure gauge

Bourdon's Tube Pressure Gauge

The pressure above or below the atmospheric pressure may be easily measured with the help of Bourdon's tube pressure gauge.

- A

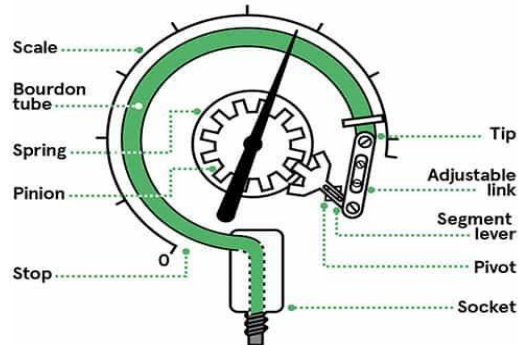

Bourdon's tube pressure gauge consists of an elliptical tube bent into an arc of a circle. This bent-up tube is called Bourdon's tube.

- When the gauge tube is connected to the fluid (whose pressure is required to be found out), the fluid under pressure

flows into the tube.

- The Bourdon's tube as a result of the increased pressure tends to straighten itself. Since the tube is encased in a circular cover, therefore it tends to become circular instead of straight.
- With the help of simple pinion and sector arrangement the elastic deformation of the Bourdon's tube rotates the pointer.
- These pointer moves over a calibrated scale which directly gives the pressure.

Numerical problems:

Q.1 The right limb of a simple U-tube manometer containing mercury is open to the atmosphere while the left limb is connected to a pipe in which a fluid of sp gravity 0.9 is flowing. The centre of the pipe is 12cm below the level of mercury in the right limb. Find the pressure of fluid in the pipe if the difference of mercury level in the two limbs is 20 cm.

Q.2 A single column manometer is connected to a pipe containing a liquid of sp. Gravity 0.9 find the pressure in the pipe if the area of the reservoir is 100 times the area of the tube for manometer reading. The sp. Gravity of mercury is 13.6.

Q.3 a differential manometer is connected at the two points A and B of two pipes. The pipe A contains a liquid of sp. Gravity =1.5 while pipe B contains a liquid of sp. Gravity 0.9 the pressure at A and B are 1 kg/cm^2 and 1.80 kg/cm^2 respectively. Find the difference in mercury level in the differential manometer.

Q.4 water is flowing through two difference pipes to which an inverted differential manometer having an oil of sp. Gravity 0.8 is connected. The pressure head in the pipe A is 2m of water, find the pressure in the pipe B for the manometer readings.

HYDROSTATICS

It is defined as the study of pressure exerted by a liquid at rest. The direction of such pressure is always perpendicular to the surface on which it acts.

Total Pressure: It is defined as the force exerted by a static fluid on a surface either plane or curved when the fluid comes in contact with the surface.

Centre of pressure: It is defined as the point of application of the total pressure on the surface.

There are four cases of submerged surfaces on which the total pressure force and the centre of pressure is to be determined.

This submerged surface may be-

1. Horizontal plane surface
2. Vertical plane surface
3. Inclined surface
4. Curve surface

Total pressure force & depth of centre of pressure on horizontal immersed surface.

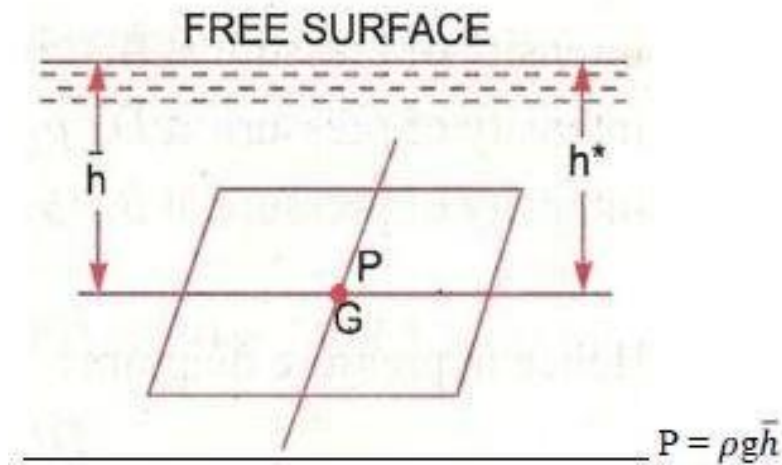

Consider a plane horizontal surface immersed in a static fluid as every point of the surface is at the same depth from the free surface of the liquid.

The pressure intensity will be equal on the entire surface and equal to $P = \rho g h$

Where, ρ = density of the liquid

h = depth of surface

Total pressure force F on the surface,

$$F = P \times \text{Area}$$

$$= \rho g h \times \text{Area}$$

$$F = \rho g A \bar{h}$$

Where, h^* = depth of centre of pressure from free surface equal to h .

$h(\bar{h})$ = depth of C.G. from free surface of liquid h .

Total pressure force & depth of centre of pressure on horizontal immersed surface.

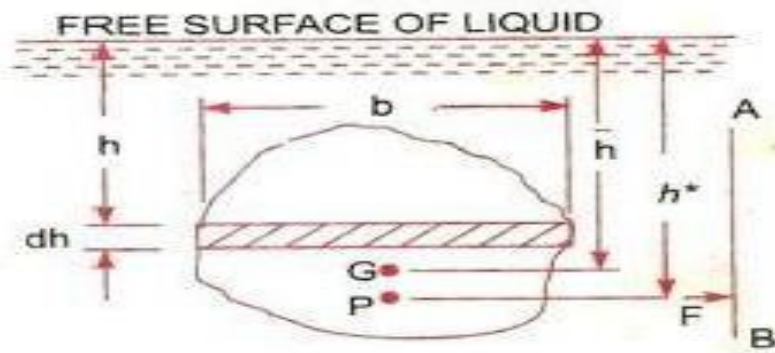

Consider a vertical plane surface of any shape immersed in a liquid.

Let,

A = total area of the surface

\bar{h} = distance of C.G. of the area from free surface of liquid.

G = centre of gravity of plane surface.

h^* = distance of centre of pressure (P) from the surface of liquid.

Total Pressure: The total pressure on the surface may be determined by dividing the entire surface into a number of small parallel strip.

The force on small strip calculated and the total pressure force on the whole area is calculated by integrating the force on small strip.

Consider a strip of thickness ' dh ' and width ' b ' at a depth ' h ' from free surface of liquid.

Area of the small strip = $b \times dh$

Total pressure on strip $\Rightarrow dF = P \times \text{Area}$

$$= \rho g h \times b dh$$

Total pressure force on the whole surface,

$$F = \int dF$$

$$= \int \rho g h \times b dh$$

$$= \rho g \int h \times b dh$$

$$= \rho g \int h \times dA$$

But, $\int h \times dA$ = moment of surface area about the free surface of liquid.

= area of the surface \times distance of C.G. from free surface.

$$F = \rho g A \bar{h}$$

Depth of centre of pressure

The intensity of pressure on an immersed surface is not uniform.

The intensity of pressure is higher at the lower portion of vertical surface as compared to upper surface, when the vertical surface is immersed in static liquid,

Centre of pressure is calculated by using the principle of moments which states that, “the moment of the resultant force about an axis is equal to the sum of moments of the components about the same axis”.

The resultant force ‘F’ acting at a point P at a distance ‘h*’ from free surface of the liquid.

Hence moment of the force F about free surface of the liquid = Fxh*-----(1)

Moment of force dF acting on a stream about the free surface of liquid.

$$\begin{aligned}
 &= dF \times h \\
 &= P \times bdh \times h \\
 &= \rho gh \times dA \times h \\
 &= \rho gh^2 dA
 \end{aligned}$$

Sum of moment of all such surface about free surface of liquid

$$\begin{aligned}
 &= \int \rho gh^2 dA \\
 &= \rho g \int h^2 dA \\
 &= \rho g I_0 \text{-----} (2)
 \end{aligned}$$

I_0 = integration of $h^2 dA$ = moment of inertia of the surface about free surface of liquid.

Now equating two equations we get:

$$\begin{aligned}
 Fxh^* &= \rho g I_0 \\
 \rho g A \bar{h} x h^* &= \rho g I_0 \\
 h^* &= \frac{\rho g I_0}{\rho g A \bar{h}} \\
 h^* &= \frac{I_0}{A \bar{h}} \text{-----} (3)
 \end{aligned}$$

According to parallel axis theorem of moment of inertia,

$$I_0 = I_G + Ah^2$$

Putting the value of I_0 in equation (3),

$$h^* = \frac{I_G + Ah^2}{A \bar{h}}$$

$$h^* = \frac{IG}{Ah} + h^-$$

Therefore, centre of pressure lies below the centre of gravity 'g'.

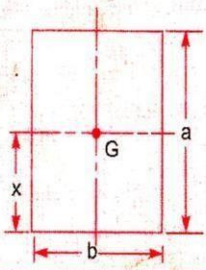
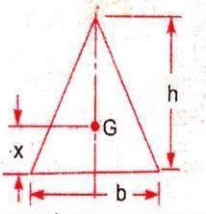
Plane surface	C.G. from the base	Area	Moment of inertia about an axis passing through C.G. and parallel to base (I_G)	Moment of inertia about base (I_0)
<p>1. Rectangle</p> 	$x = \frac{d}{2}$	bd	$\frac{bd^3}{12}$	$\frac{bd^3}{3}$
<p>2. Triangle</p> 	$x = \frac{h}{3}$	$\frac{bh}{2}$	$\frac{bh^3}{36}$	$\frac{bh^3}{12}$

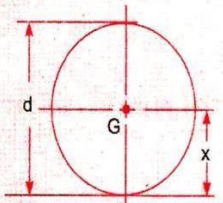
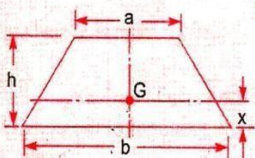
Plane surface	C.G. from the base	Area	Moment of inertia about an axis passing through C.G. and parallel to base (I_G)	Moment of inertia about base (I_0)
<p>3. Circle</p> 	$x = \frac{d}{2}$	$\frac{\pi d^2}{4}$	$\frac{\pi d^4}{64}$	—
<p>4. Trapezium</p> 	$x = \left(\frac{2a+b}{a+b}\right) \frac{h}{3}$	$\frac{(a+b)}{2} \times h$	$\left(\frac{a^2 + 4ab + b^2}{36(a+b)}\right) \times h^3$	—

Horizontal plane surface submerged in liquid:

Consider a plane horizontal surface immersed in a static fluid as every point of the surface is at the same depth from the free surface of the liquid, the pressure intensity will be equal on the entire surface.

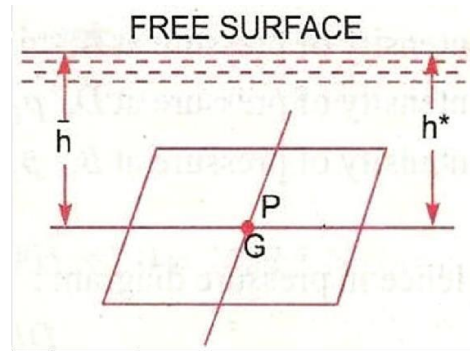

$$P = \rho g \bar{h}$$

We know that pressure force, $F = P \times A$

Then total pressure force acting on horizontal surface immersed in a liquid

$$= \rho g A \bar{h}$$

Archimedes principle:

When a body is immersed in a fluid either wholly or partially, it is buoyed or lifted up by a force, which is equal to the weight of fluid displaced by the body.

Buoyancy:

Whenever a body is immersed wholly or partially in a fluid it is subjected to an upward force which tends to lift it up. This tendency for an immersed body to be lifted up in the fluid due to an upward force opposite to action of gravity is known as buoyancy this upward force is known as force of buoyancy.

Centre of Buoyancy:

It is defined as the point through which the force of buoyancy is supposed to act. The force of buoyancy is a vertical force and is equal to the weight of the fluid displaced by the body.

Center of buoyancy will be the centre of gravity of the fluid displaced.

Meta-centre:

It is defined as the point about which a body starts oscillating when the body is tilted by a small angle. The meta centre may also be defined as the point at which the line of action of the force of buoyancy will meet the normal axis of the body when the body is given a small angular displacement.

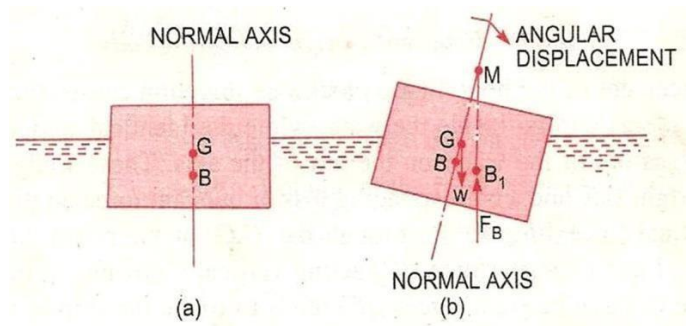

Meta centre height:

The distance between the meta centre of a floating body and the centre of gravity of the body is called meta-centric height i.e the distance MG .

Concept of flotation:

Flotation:

When a body is immersed in any fluid, it experiences two forces. First one is the weight of body W acting vertically downwards, second is the buoyancy force F_b acting vertically upwards. In case W is greater than F_b , the weight will cause the body to sink in the fluid. In case $W = F_b$ the body will remain in equilibrium at any level. In case W is small than F_b the body will move upwards in fluid. The body moving up will come to rest or top moving up in fluid when the fluid displaced by its submerged part is equal to its weight W , the body in this situation is said to be floating and this phenomenon is known as flotation.

Principle of flotation:

The principle of flotation states that the weight of the floating body is equal to the weight of the fluid displaced by the body.

Numerical

1. Find the volume of the water displaced & position of centre of buoyancy for a wooden block of width 2.5m & of depth 1.5m when it floats horizontally in water. The density of wooden block is 650 kg/m³. & Its length 6.0m.
2. A rectangular plane surface 2m wide and 3m deep lies in water in such a way that its plane makes an angle of 30° with the free surface of water. Determine the total pressure and position of center of pressure when the upper edge is 1.5m below the free water surface
3. Determine the total pressure on a circular plate of diameter 1.5 m which is placed vertically in water in such a way that the centre of plate is 2 m below the free surface of water. Find the position of centre of pressure also.

KINEMATICS OF FLOW

TYPES OF FLOW: -

The fluid flow is classified as follows:

- **Steady And Unsteady Flow**
- **Uniform And Non- Uniform Flows**
- **Laminar And Turbulant Flows**
- **Compressible And Incompressible Flows**
- **Rotational And Irrotational Flows**
- **One, Two, Three-Dimensional Flow**

➤ **STEADY AND UNSTEADY FLOW:** -

1. Steady flow: -

Steady flow is defined as that type of flow in which the fluid characteristics like velocity, pressure, density at a point do not change with time.

Thus, mathematically

$$\left(\frac{\partial v}{\partial t}\right) = 0, \left(\frac{\partial p}{\partial t}\right) = 0, \left(\frac{\partial J}{\partial t}\right) = 0;$$

Unsteady flow: -

Unsteady flow is defined as that type of flow in which the velocity, pressure, and density at a point changes w.r.t time.

Thus, mathematically

$$\left(\frac{\partial v}{\partial t}\right) \neq 0, \left(\frac{\partial p}{\partial t}\right) \neq 0, \left(\frac{\partial J}{\partial t}\right) \neq 0$$

➤ **UNIFORM AND NON- UNIFORM FLOWS: -**

1. **Uniform flow: -**

It is defined as the flow in which velocity of flow at any given time does not change w.r.t length of flow or space.

Mathematically,

$$\left(\frac{\partial v}{\partial t}\right)_{t \text{ is a constant}} = 0$$

2. **Non- uniform flows: -**

It is defined as the flow in which velocity of flow at any given time changes w.r.t length of flow. Mathematically,

$$\left(\frac{\partial v}{\partial t}\right)_{t \text{ is a constant}} \neq 0$$

➤ **LAMINAR AND TURBULANT FLOWS: -**

1. **Laminar flow: -**

Laminar flow is that type of flow in which the fluid particles are moved in a well-defined path called streamlines. The paths are parallel and straight to each other.

2. **Turbulent flow: -**

Turbulent flow is that type of flow in which the fluid particles

are moved in a zig-zag manner.

For a pipe flow the type of flow is determined by Reynolds number

$$(\text{Re}) = \frac{VD}{\nu}$$

Where V = mean velocity of flow

D = diameter of pipe

ν = kinematic viscosity

If $\text{Re} < 2000$, then flow is laminar flow. If $\text{Re} > 4000$, then flow is turbulent flow.

If Re lies in between 2000 and 4000, the flow may be laminar or turbulent.

➤ COMPRESSIBLE AND INCOMPRESSIBLE FLOWS:-

1. Compressible flow: -

Compressible flow is that type of flow in which the density of fluid changes from point to point.

So, $\rho \neq \text{constant}$.

2. Incompressible flow: -

Incompressible flow is that type of flow in which the density is constant for the fluid flow.

So, $\rho = \text{constant}$

➤ ROTATIONAL AND IRROTATIONAL FLOWS:-

1. Rotational flow: -

Rotational flow is that type of flow in which the fluid particles while flowing along stream lines also rotate about their own axis.

2. Ir-rotational flow: -

Irrotational flow is that type of flow in which the fluid particles while flowing along streamlines do not rotate about their own axis.

➤ **ONE, TWO, THREE-DIMENSIONAL FLOW: -**

1. **One dimensional flow: -**

One dimension flow is defined as that type of flow in which velocity is a function of time and one space co-ordinate only.

For a steady one-dimensional flow, the velocity is a function of one space co-ordinate only.

$$\begin{aligned}\text{So, } U &= \\ &f(x), V \\ &= 0, \\ W &= 0\end{aligned}$$

U, V and W are velocity components in x, y, z direction respectively.

2. **Two-dimensional flow: -**

Two-dimensional flow is the flow in which velocity is a function of time and 2- space co-ordinates only. For a steady 2- dimensional flow the velocity is a function of two – space co-ordinate only.

$$\begin{aligned}\text{So, } U &= f_1(x,y) , \\ V &= f_2(x,y) \\ ,W &= 0\end{aligned}$$

3. **Three-dimensional flow: -**

Three – dimensional flow is the flow in which velocity is a function of time and 3- space co-ordinates only. For steady three-dimensional flow, the velocity is a function of three space co-ordinates only.

$$\begin{aligned}\text{So, } U &= f_1(x, y, z) \\ V &= f_2(x, y, z) \\ W &= f_3(x, y, z)\end{aligned}$$

Rate of flow or discharge

It is defined as the quantity of a fluid flowing per second

through a section of pipe.

For an incompressible fluid the rate of flow or discharge is expressed as the volume of fluid flowing across the section per second.

For compressible fluids, the rate of flow is usually expressed as the weight of fluid flowing across the section.

$$Q = A \cdot V$$

Where A = cross sectional area of the pipe

V = velocity of fluid across the section

Equation of continuity:

It is based on the principle of conservation of mass. For a fluid flowing through the pipe at all the cross-section, the quantity of fluid per second is constant.

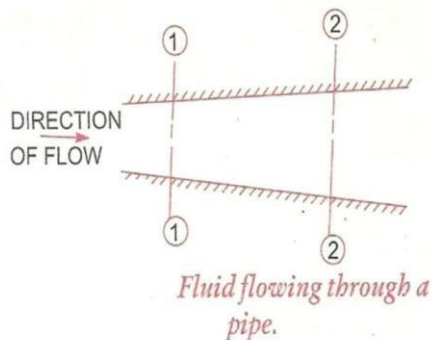

Let V_1 = average velocity at cross-section 1-1.

ρ_1 = density at cross-section 1-1

A_1 = area of pipe at section

1-1

V_2 = average velocity at cross-section 2-2

ρ_2 = density at cross-section

2-2

A_2 = area of pipe at section

2-2

The rate of flow at section 1-1 $=\rho_1 A_1 V_1$

The rate of flow at section 2-2 $=\rho_2 A_2 V_2$

According to laws of conservation of mass rate of flow at section 1-1 is equal to the rate of flow at section 2-2,

$$\rho_1 A_1 V_1 = \rho_2 A_2 V_2$$

This is called continuity equation.

If the fluid is compressible, then

$$\rho_1 = \rho_2,$$

so $A_1 V_1 = A_2 V_2$

“If no fluid is added removed from the pipe in any length, then the mass passing across different sections shall be same”

Simple Problems

Problem: -1

The diameters of a pipe at the sections 1 and 2 are 10cm and 15cm respectively. Find the discharge through the pipe if the velocity of the water flowing through the pipe at section 1 is 5m/s. Determine also the velocity at section 2.

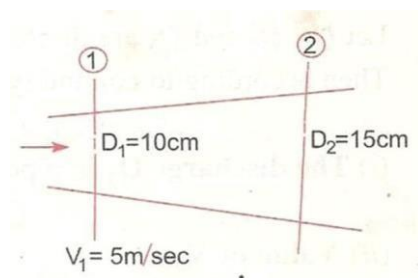

Problem: -2

A 30cm diameter pipe conveying water branches into two pipes of diameter 20cm and 15cm respectively. If the average velocity in the 30cm diameter pipe is 2.5 m/s, find the discharge in this pipe. Also determine the velocity in 15cm pipe if the

Solution. Given :

At section 1,

$$D_1 = 30 \text{ cm} = 0.3 \text{ m}$$

$$A_1 = \frac{\pi}{4} (D_1)^2 = \frac{\pi}{4} (0.3)^2 = 0.07068 \text{ m}^2$$

$$V_1 = 2.5 \text{ m/s.}$$

At section 2,

$$D_2 = 20 \text{ cm} = 0.2 \text{ m}$$

$$A_2 = \frac{\pi}{4} (0.2)^2 = 0.03142 \text{ m}^2$$

(i) Discharge through pipe is given by equation (5.1)

or

$$Q = A_1 \times V_1$$

$$= 0.07068 \times 2.5 = 0.1767 \text{ m}^3/\text{s. Ans.}$$

Using equation (5.3), we have $A_1 V_1 = A_2 V_2$

$$(ii) \therefore V_2 = \frac{A_1 V_1}{A_2} = \frac{0.1767}{0.03142} \times 2.5 = 14.0 \text{ m/s.}$$

average velocity in 20cm diameter pipe is 14m/s.

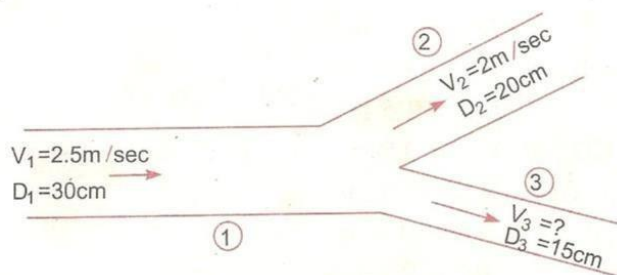

Given Data:

$$D_1 = 30 \text{ cm} = 0.3 \text{ m}$$

$$A_1 = \frac{\pi}{4} (D_1)^2$$

$$= \frac{\pi}{4} (0.3)^2 = 0.07068 \text{ m}^2$$

$$V_1 = 2.5 \text{ m/s}$$

$$D_2 = 20\text{cm} = 0.2\text{m}$$

$$A_2 = \pi (0.2)^2 / 4 = 0.0314 \text{ m}^2$$

$$V_2 = 2\text{m/s}$$

$$D_3 = 15\text{cm} = 0.15\text{m}$$

$$A_3 = \pi (0.15^2) / 4 = 0.01767 \text{ m}^2$$

Let Q_1 , Q_2 , Q_3 are discharges in pipe 1, 2, 3 respectively

$$Q_1 = Q_2 + Q_3$$

The discharge Q_1 in pipe 1 is given as

$$Q_1 = A_1 V_1$$

$$= 0.07068 \times 2.5 \text{ m}^3/\text{s}$$

$$Q_2 = A_2 V_2$$

$$= 0.0314 \times 2.0 = 0.0628 \text{ m}^3/\text{s}$$

Substituting the values of Q_1 and Q_2 on the above equation we

$$0.1767 = 0.0628 + Q_3$$

$$Q_3 = 0.1767 - 0.0628$$

$$= 0.1139 \text{ m}^3/\text{s}$$

Again $Q_3 = A_3 V_3$

$$= 0.01767 \times V_3 \Rightarrow 0.1139 = 0.01767 \times V_3$$

$$V_3 = 0.1139/0.01767$$

$$= 6.44 \text{ m/s}$$

Problem: -4

A 25 cm diameter pipe carries oil of sp. Gr. 0.9 at a velocity of 3m/s. At another section the diameter is 20cm. Find the velocity at this section and also mass rate of flow of oil.

Solution. Given :

at section 1,

$$D_1 = 25 \text{ cm} = 0.25 \text{ m}$$

$$A_1 = \frac{\pi}{4} D_1^2 = \frac{\pi}{4} \times .25^2 = 0.049 \text{ m}^2$$

$$V_1 = 3 \text{ m/s}$$

at section 2,

$$D_2 = 20 \text{ cm} = 0.2 \text{ m}$$

$$A_2 = \frac{\pi}{4} (.2)^2 = 0.0314 \text{ m}^2$$

$$V_2 = ?$$

Mass rate of flow of oil = ?

Applying continuity equation at sections 1 and 2,

$$A_1 V_1 = A_2 V_2$$

or $0.049 \times 3.0 = 0.0314 \times V_2$

$$\therefore V_2 = \frac{0.049 \times 3.0}{.0314} = \mathbf{4.68 \text{ m/s. Ans.}}$$

Mass rate of flow of oil = Mass density $\times Q = \rho \times A_1 \times V_1$

Sp. gr. of oil = $\frac{\text{Densit of oil}}{\text{Densit of water}}$

\therefore Density of oil = Sp. gr. of oil \times Density of water

$$= 0.9 \times 1000 \text{ kg/m}^3 = \frac{900 \text{ kg}}{\text{m}^3}$$

\therefore Mass rate of flow = $900 \times 0.049 \times 3.0 \text{ kg/s} = \mathbf{132.23 \text{ kg/s. Ans.}}$

Bernoulli's Theorem:

According to Bernoulli's theorem, the sum of the energies possessed by a flowing ideal liquid at a point is constant provided that the liquid is incompressible and non-viscous and flow in streamline.

Potential energy + Kinetic energy + Pressure energy = Constant

Mathematically, $Z + V^2/2g + p/w = \text{constant}$

Where, Z = potential energy, $V^2/2g$ = Kinetic energy, P/W = pressure energy

Prove: - Consider a perfect incompressible liquid, flowing through a non-uniform pipe as shown in the figure.

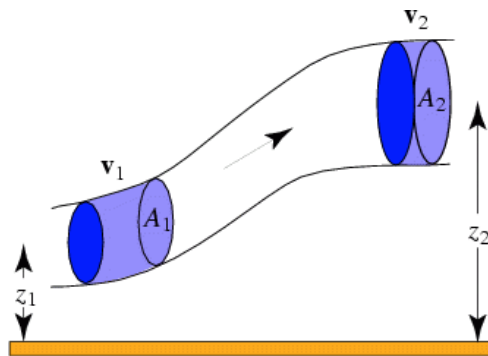

Let us consider two sections AA & BB of the pipe. Now let us assume that the pipe is running full and there is a continuity of flow between the two sections.

Let Z_1 = Height of AA above the datum.

P_1 = Pressure at AA.

V_1 = Velocity of liquid at AA,

a_1 = cross-sectional area of the pipe at AA, and Z_2, P_2, V_2, a_2 = corresponding values at BB.

Let the liquid between the two sections AA and BB moves to A^1A^1 and B^1B^1 through very small lengths

$d l_1$ and $d l_2$ as shown in fig. This movement of the liquid between AA & BB is equivalent to the movement of the liquid between AA and A^1A^1 to BB and B^1B^1 the remaining liquid between A^1A^1 and BB being unaffected.

Let W be the weight of the liquid between AA and A^1A^1 . Since the flow is continuous,

$$\text{Therefore } W = w a_1 d l_1 = w a_2 d l_2 \Rightarrow a_1 d l_1 = a_2 d l_2 = W/w \text{----- (1)}$$

$$\text{Or } a_1 d l_1 = a_2 d l_2 \text{----- (ii)}$$

We know that work done by pressure at AA in moving the liquid to A¹A¹ = force × distance = p₁a₁d l₁

Similarly, work done by pressure at BB, in moving the liquid to B¹B¹ = - P₂a₂d l₂ (minus sign is taken as the direction of p₂ is opposite to that of p₁)

$$\begin{aligned} \text{Total work done by the pressure} &= P_1 a_1 d l_1 - P_2 a_2 d l_2 \\ &= P_1 a_1 d l_1 - P_2 a_1 d l_1, \{ \text{Due to } a_1 d l_1 = a_2 d l_2 \} \\ &= a_1 d l_1 (P_1 - P_2) = W/w (P_1 - P_2), \{ \text{Due to } a_1 d l_1 = W/w \} \end{aligned}$$

$$\begin{aligned} \text{Loss of potential energy} &= w (z_1 - z_2) \text{ \& again in kinetic energy } = w (V_2^2/2g - V_1^2/2g) \\ &= w/2g (V_2^2 - V_1^2) \end{aligned}$$

We know that loss of potential energy + work done by pressure

$$W (Z_1 - Z_2) + W/w (P_1 - P_2) = W/2g (V_2^2 - V_1^2)$$

$$(Z_1 - Z_2) + P_1/w - P_2/w = V_2^2/2g - V_1^2/2g$$

$$\text{Or } Z_1 + V_1^2/2g + P_1/w = Z_2 + V_2^2/2g + P_2/w$$

Which proves the Bernoulli's equation

Assumptions

The following are the assumptions made in the derivation of Bernoulli's equation.

- (i) The fluid is ideal, i.e., viscosity is zero.
- (ii) The flow is steady
- (iii) The flow is incompressible
- (iv) The flow is irrotational

Limitations of Bernoulli's equation: The Bernoulli's theorem or Bernoulli's equation has been derived on certain assumptions, which are rarely possible. Thus, the Bernoulli's theorem has the following limitations.

(1) The Bernoulli's equation has been derived under the assumption that the velocity of every liquid particle across any cross-section of a pipe, is uniform. But in actual practice, it is not so. The velocity of liquid particle in the centre of a pipe is maximum & gradually decreases towards the walls of the pipe due to the pipe friction. Thus, while using the Bernoulli's equation, only the mean velocity of the liquid should be taken into account.

(2) The Bernoulli's equation has been derived under the assumption that no external force, except the gravity force is acting on the liquid. But in actual practice, it is not so. There are always some external force (such as pipe friction etc) acting the liquid, which effect the flow of the liquid.

Thus, while using the Bernoulli's equation, all such external force should be neglected. But if some energy is supplied to, or, extracted from the flow the same should also be taken into account.

(3) The Bernoulli's equation has been derived, under the assumption that there is no loss of energy of the liquid particle while flowing. But in actual practice, it is rarely so. In a turbulent flow, some kinetic energy is converted into heat energy. And in a viscous flow, some energy is lost due to shear forces. Thus, while using Bernoulli's equation, all such losses should be neglected.

(4) If the liquid is flowing in a curved path, the energy due to centrifugal force should also be taken into account.

Problem: - 5

Water is flowing through a pipe of 5cm diameter under a pressure of 29.43 N/cm² (gauge) and with mean velocity of 2.0 m/s. Find the total head or total energy per unit weight of the water at a cross-section, which is 5m above the datum line.

Solution. Given :

Diameter of pipe

$$= 5 \text{ cm} = 0.5 \text{ m}$$

Pressure,

$$p = 29.43 \text{ N/cm}^2 = 29.43 \times 10^4 \text{ N/m}^2$$

Velocity,

$$v = 2.0 \text{ m/s}$$

Datum head,

$$z = 5 \text{ m}$$

Total head

$$= \text{pressure head} + \text{kinetic head} + \text{datum head}$$

Pressure head

$$= \frac{p}{\rho g} = \frac{29.43 \times 10^4}{1000 \times 9.81} = 30 \text{ m} \quad \left\{ \rho \text{ for water} = 1000 \frac{\text{kg}}{\text{m}^3} \right\}$$

Kinetic head

$$= \frac{v^2}{2g} = \frac{2 \times 2}{2 \times 9.81} = 0.204 \text{ m}$$

∴ Total head

$$= \frac{p}{\rho g} + \frac{v^2}{2g} + z = 30 + 0.204 + 5 = 35.204 \text{ m. Ans.}$$

Problem: - 6

A pipe, through which water is flowing, is having diameters, 20cm and 10cm at the cross sections 1 and 2 respectively. The velocity of water at section 1 is given 4.0 m/s. Find the velocity head at sections 1 and 2 and also rate of discharge.

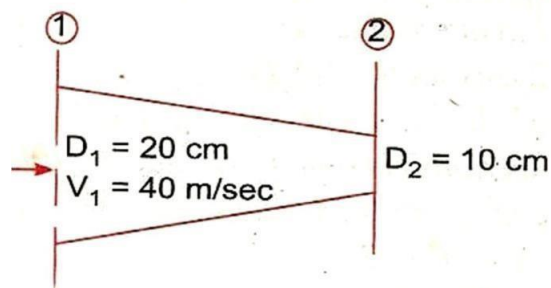

Solution. Given :

$$D_1 = 20 \text{ cm} = 0.2 \text{ m}$$

∴ Area,

$$A_1 = \frac{\pi}{4} D_1^2 = \frac{\pi}{4} (.2)^2 = 0.0314 \text{ m}^2$$

$$V_1 = 4.0 \text{ m/s}$$

$$D_2 = 0.1 \text{ m}$$

∴

$$A_2 = \frac{\pi}{4} (.1)^2 = .00785 \text{ m}^2$$

(i) Velocity head at section 1

$$= \frac{V_1^2}{2g} = \frac{4.0 \times 4.0}{2 \times 9.81} = \mathbf{0.815 \text{ m. Ans.}}$$

(ii) Velocity head at section 2 = $V_2^2/2g$

To find V_2 , apply continuity equation at 1 and 2

$$\therefore A_1 V_1 = A_2 V_2 \quad \text{or} \quad V_2 = \frac{A_1 V_1}{A_2} = \frac{.0314}{.00785} \times 4.0 = 16.0 \text{ m/s}$$

$$\therefore \text{Velocity head at section 2} = \frac{V_2^2}{2g} = \frac{16.0 \times 16.0}{2 \times 9.81} = \mathbf{83.047 \text{ m. Ans.}}$$

(iii) Rate of discharge

$$= A_1 V_1 \quad \text{or} \quad A_2 V_2 \\ = 0.0314 \times 4.0 = 0.1256 \text{ m}^3/\text{s}$$

Application of Bernoulli's equation:

Bernoulli's equation is applied in all problems of incompressible fluid flow where energy consideration is involved.

It is also applied to following measuring devices

1. Venturi meter
2. Orifice meter
3. Pitot tube

Venturi meter:

A venturi meter is a device used for measuring the rate of a flow of a fluid flowing through a pipe it consists of three parts.

- I. Short converging part
- II. Throat
- III. Diverging part

Expression for rate of flow through venturi meter:

Consider a venturi meter is fitted in a horizontal pipe through which a fluid is flowing

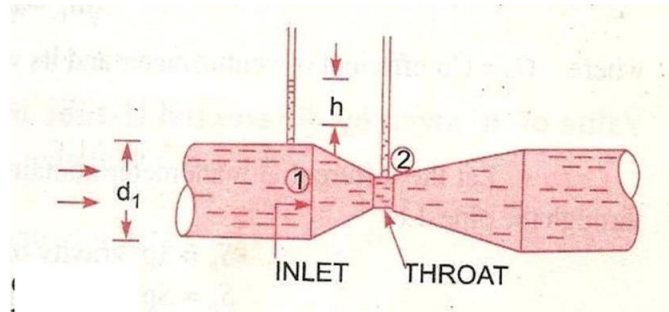

Let d_1 = diameter at inlet or at section (1)

P_1 = pressure at section (1)

V_1 = velocity of fluid at section (1)

A_1 = area at section (1) = $\pi d_1^2/4$

D_2, p_2, v_2, a_2 are corresponding values at section 2
applying Bernoulli's equation at sections 1 and 2 we get

$$\frac{p_1}{\rho g} + \frac{v_1^2}{2g} + z_1 = \frac{p_2}{\rho g} + \frac{v_2^2}{2g} + z_2$$

As pipe is horizontal, hence $z_1 = z_2$

$$\therefore \frac{p_1}{\rho g} + \frac{v_1^2}{2g} = \frac{p_2}{\rho g} + \frac{v_2^2}{2g} \quad \text{or} \quad \frac{p_1 - p_2}{\rho g} = \frac{v_2^2}{2g} - \frac{v_1^2}{2g}$$

But $\frac{P_1 - P_2}{\rho g}$ is the difference of pressure heads at sections 1 and 2

and it is equal to h

$$\text{So, } h = \frac{v_2^2}{2g} - \frac{v_1^2}{2g}$$

Now applying continuity equation at sections 1 & 2 $a_1 v_1 = a_2 v_2$

$$v_1 = a_2 v_2 / a_1$$

$$h = \frac{v_2^2}{2g} - \frac{\left(\frac{a_2 v_2}{a_1}\right)^2}{2g} = \frac{v_2^2}{2g} \left[1 - \frac{a_2^2}{a_1^2}\right] = \frac{v_2^2}{2g} \left[\frac{a_1^2 - a_2^2}{a_1^2}\right]$$

$$v_2^2 = 2gh \frac{a_1^2}{a_1^2 - a_2^2}$$

$$v_2 = \sqrt{2gh \frac{a_1^2}{a_1^2 - a_2^2}} = \frac{a_1}{\sqrt{a_1^2 - a_2^2}} \sqrt{2gh}$$

$$Q = a_2 v_2$$

$$= a_2 \frac{a_1}{\sqrt{a_1^2 - a_2^2}} \times \sqrt{2gh} = \frac{a_1 a_2}{\sqrt{a_1^2 - a_2^2}} \times \sqrt{2gh}$$

Where Q = Theoretical discharge

Actual discharge will be less than theoretical discharge

$$Q_{\text{act}} = C_d \times \frac{a_1 a_2}{\sqrt{a_1^2 - a_2^2}} \times \sqrt{2gh}$$

Where C_d = co-efficient of venturimeter and value is less than 1

PITOT TUBE:

A pitot tube an instrument to determine the velocity of flow at the required point in a pipe or a stream in its simplest form a pitot tube consists of a glass tube bent through 90° as shown in figure.

The lower end of the tube poses the direction of the flow as shown in figure. The liquid rises up in the tube due to pressure exerted by the flowing liquid by measuring the rise of liquid in the tube, we can find out the velocity of the liquid flow.

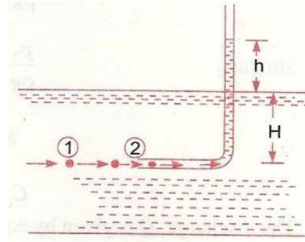

Let h - height of the liquid in the pitot tube above the surface.

H - depth of tube in the liquid end

V - velocity of the liquid

Applying Bernoulli's equation for the section 1 and 2.

$$H + \frac{V_2^2}{2g} = H + h \quad (Z_1 = Z_2)$$

$$H = \frac{v_2^2}{2g}$$

$$V = \sqrt{2gh}$$

Problem: - 7

Water is flowing through a pipe of 5cm diameter under a pressure of 29.43 N/cm² (gauge) and with mean velocity of 2.0 m/s. Find the total head or total energy per unit weight of the water at a cross-section, which is 5m above the datum line.

Solution. Given :

Diameter of pipe

$$= 5 \text{ cm} = 0.05 \text{ m}$$

Pressure,

$$p = 29.43 \text{ N/cm}^2 = 29.43 \times 10^4 \text{ N/m}^2$$

Velocity,

$$v = 2.0 \text{ m/s}$$

Datum head,

$$z = 5 \text{ m}$$

Total head

$$= \text{pressure head} + \text{kinetic head} + \text{datum head}$$

Pressure head

$$= \frac{p}{\rho g} = \frac{29.43 \times 10^4}{1000 \times 9.81} = 30 \text{ m} \quad \left\{ \rho \text{ for water} = 1000 \frac{\text{kg}}{\text{m}^3} \right\}$$

Kinetic head

$$= \frac{v^2}{2g} = \frac{2 \times 2}{2 \times 9.81} = 0.204 \text{ m}$$

\therefore Total head

$$= \frac{p}{\rho g} + \frac{v^2}{2g} + z = 30 + 0.204 + 5 = 35.204 \text{ m. Ans.}$$

Problem: - 8

The water is flowing through a pipe having diameters 20 cm and 10 cm

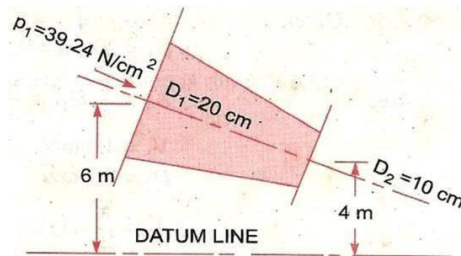

at sections 1 and 2 respectively. The rate of flow through pipe is 35lit/s. The section 1 is 6m above datum and section 2 is 4m above datum. If the pressure at section 1 is 39.24 N/cm². Find the intensity of pressure

At section 1,

$$D_1 = 20 \text{ cm} = 0.2 \text{ m}$$

$$A_1 = \frac{\pi}{4} (.2)^2 = .0314 \text{ m}^2$$

$$p_1 = 39.24 \text{ N/cm}^2 \\ = 39.24 \times 10^4 \text{ N/m}^2$$

$$z_1 = 6.0 \text{ m}$$

At section 2,

$$D_2 = 0.10 \text{ m}$$

$$A_2 = \frac{\pi}{4} (0.1)^2 = .00785 \text{ m}^2$$

$$z_2 = 4 \text{ m}$$

$$p_2 = ?$$

Rate of flow,

$$Q = 35 \text{ lit/s} = \frac{35}{1000} = .035 \text{ m}^3/\text{s}$$

Now

$$Q = A_1 V_1 = A_2 V_2$$

∴

$$V_1 = \frac{Q}{A_1} = \frac{.035}{.0314} = 1.114 \text{ m/s}$$

and

$$V_2 = \frac{Q}{A_2} = \frac{.035}{.00785} = 4.456 \text{ m/s}$$

at section 2

Applying Bernoulli's equation at sections 1 and 2, we get

$$\frac{p_1}{\rho g} + \frac{V_1^2}{2g} + z_1 = \frac{p_2}{\rho g} + \frac{V_2^2}{2g} + z_2$$

$$\text{or } \frac{39.24 \times 10^4}{1000 \times 9.81} + \frac{(1.114)^2}{2 \times 9.81} + 6.0 = \frac{p_2}{1000 \times 9.81} + \frac{(4.456)^2}{2 \times 9.81} + 4.0$$

$$\text{or } 40 + 0.063 + 6.0 = \frac{p_2}{9810} + 1.012 + 4.0$$

$$\text{or } 46.063 = \frac{p_2}{9810} + 5.012$$

$$\therefore \frac{p_2}{9810} = 46.063 - 5.012 = 41.051$$

$$\begin{aligned} \therefore p_2 &= 41.051 \times 9810 \text{ N/m}^2 \\ &= \frac{41.051 \times 9810}{10^4} \text{ N/cm}^2 = \mathbf{40.27 \text{ N/cm}^2}. \end{aligned}$$

Problem: - 9

Water is flowing through a pipe having diameter 300mm and 200 mm at the bottom and upper end respectively. The intensity of pressure at the bottom end is 9.81N/m². Determine the difference in datum head if the rate of flow through pipe is 40 lit/s

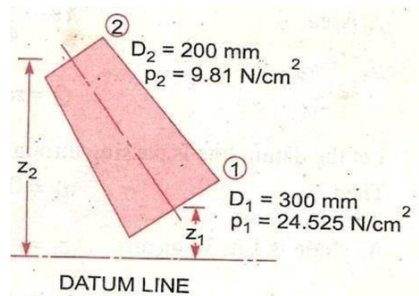

Solution. Given :

- Section 1,** $D_1 = 300 \text{ mm} = 0.3 \text{ m}$
 $p_1 = 24.525 \text{ N/cm}^2 = 24.525 \times 10^4 \text{ N/m}^2$
- Section 2,** $D_2 = 200 \text{ mm} = 0.2 \text{ m}$
 $p_2 = 9.81 \text{ N/cm}^2 = 9.81 \times 10^4 \text{ N/m}^2$
- Rate of flow = 40 lit/s

or $Q = \frac{40}{1000} = 0.04 \text{ m}^3/\text{s}$

Now $A_1 V_1 = A_2 V_2 = \text{rate of flow} = 0.04$

$\therefore V_1 = \frac{.04}{A_1} = \frac{.04}{\frac{\pi}{4} D_1^2} = \frac{0.04}{\frac{\pi}{4} (0.3)^2} = 0.5658 \text{ m/s}$
 $\approx 0.566 \text{ m/s}$

$V_2 = \frac{.04}{A_2} = \frac{.04}{\frac{\pi}{4} (D_2)^2} = \frac{0.04}{\frac{\pi}{4} (0.2)^2} = 1.274 \text{ m/s}$

Applying Bernoulli's equation at (1) and (2), we get

$$\frac{p_1}{\rho g} + \frac{V_1^2}{2g} + z_1 = \frac{p_2}{\rho g} + \frac{V_2^2}{2g} + z_2$$

or $\frac{24.525 \times 10^4}{1000 \times 9.81} + \frac{.566 \times .566}{2 \times 9.81} + z_1 = \frac{9.81 \times 10^4}{1000 \times 9.81} + \frac{(1.274)^2}{2 \times 9.81} + z_2$

or $25 + .32 + z_1 = 10 + 1.623 + z_2$

or $25.32 + z_1 = 11.623 + z_2$

$\therefore z_2 - z_1 = 25.32 - 11.623 = 13.697 = 13.70 \text{ m}$

\therefore Difference in datum head = $z_2 - z_1 = 13.70 \text{ m. Ans.}$

Problem: - 10

A horizontal venturimetre with inlet and throat diameters 10cm and 15 cm respectively is used to measure the flow of water. The reading of differential manometer connected to the inlet and throat is 20cm of mercury. Determine the rate of flow. Take $C_d = 0.98$

Solution. Given :

Dia. at inlet, $d_1 = 30 \text{ cm}$

\therefore Area at inlet, $a_1 = \frac{\pi}{4} d_1^2 = \frac{\pi}{4} (30)^2 = 706.85 \text{ cm}^2$

Dia. at throat, $d_2 = 15 \text{ cm}$

\therefore $a_2 = \frac{\pi}{4} \times 15^2 = 176.7 \text{ cm}^2$

$C_d = 0.98$

Reading of differential manometer = $x = 20 \text{ cm}$ of mercury.

\therefore Difference of pressure head is given by (6.9)

or
$$h = x \left[\frac{S_h}{S_o} - 1 \right]$$

where $S_h = \text{Sp. gravity of mercury} = 13.6$, $S_o = \text{Sp. gravity of water} = 1$

$$= 20 \left[\frac{13.6}{1} - 1 \right] = 20 \times 12.6 \text{ cm} = 252.0 \text{ cm of water.}$$

The discharge through venturimeter is given by eqn. (6.8)

$$\begin{aligned} Q &= C_d \frac{a_1 a_2}{\sqrt{a_1^2 - a_2^2}} \times \sqrt{2gh} \\ &= 0.98 \times \frac{706.85 \times 176.7}{\sqrt{(706.85)^2 - (176.7)^2}} \times \sqrt{2 \times 9.81 \times 252} \\ &= \frac{86067593.36}{\sqrt{499636.9 - 31222.9}} = \frac{86067593.36}{684.4} \\ &= 125756 \text{ cm}^3/\text{s} = \frac{125756}{1000} \text{ lit/s} = \mathbf{125.756 \text{ lit/s.}} \end{aligned}$$

Problem: - 11

An oil of Sp.gr. 0.8 is flowing through a horizontal venturimeter having inlet diameter 20cm and throat diameter 10 cm. The oil mercury differential manometer shows a reading of 25cm. Calculate the discharge of oil through the horizontal venturimeter. Take $C_d = 0.98$

Solution. Given :

Sp. gr. of oil, $S_o = 0.8$

Sp. gr. of mercury, $S_h = 13.6$

Reading of differential manometer, $x = 25$ cm

$$\begin{aligned}\therefore \text{Difference of pressure head, } h &= x \left[\frac{S_h}{S_o} - 1 \right] \\ &= 25 \left[\frac{13.6}{0.8} - 1 \right] \text{ cm of oil} = 25 [17 - 1] = 400 \text{ cm of oil.}\end{aligned}$$

Dia. at inlet, $d_1 = 20$ cm

$$\therefore a_1 = \frac{\pi}{4} d_1^2 = \frac{\pi}{4} \times 20^2 = 314.16 \text{ cm}^2$$

$d_2 = 10$ cm

$$\therefore a_2 = \frac{\pi}{4} \times 10^2 = 78.54 \text{ cm}^2$$

$C_d = 0.98$

\therefore The discharge Q is given by equation (6.8)

or

$$\begin{aligned}Q &= C_d \frac{a_1 a_2}{\sqrt{a_1^2 - 7a_2^2}} \times \sqrt{2gh} \\ &= 0.98 \times \frac{314.16 \times 78.54}{\sqrt{(314.16)^2 - (78.54)^2}} \times \sqrt{2 \times 981 \times 400} \\ &= \frac{21421375.68}{\sqrt{98696 - 6168}} = \frac{21421375.68}{304} \text{ cm}^3/\text{s} \\ &= 70465 \text{ cm}^3/\text{s} = \mathbf{70.465 \text{ litres/s. Ans.}}\end{aligned}$$

Problem: - 12

A horizontal venturimeter with inlet and throat diameters 20cm and 10 cm respectively is used to measure the flow of oil of Sp. gr. 0.8. The discharge of oil through venturimeter is 60lit/s. Find the reading of oil-mercury differential manometer. Take $C_d = 0.98$

Solution. Given :

$$d_1 = 20 \text{ cm}$$

$$\therefore a_1 = \frac{\pi}{4} 20^2 = 314.16 \text{ cm}^2$$

$$d_2 = 10 \text{ cm}$$

$$\therefore a_2 = \frac{\pi}{4} \times 10^2 = 78.54 \text{ cm}^2$$

$$C_d = 0.98$$

$$Q = 60 \text{ litres/s} = 60 \times 1000 \text{ cm}^3/\text{s}$$

Using the equation (6.8),
$$Q = C_d \frac{a_1 a_2}{\sqrt{a_1^2 - a_2^2}} \times \sqrt{2gh}$$

or
$$60 \times 1000 = 9.81 \times \frac{314.16 \times 78.54}{\sqrt{(314.16)^2 - (78.54)^2}} \times \sqrt{2 \times 981 \times h}$$

or
$$\sqrt{h} = \frac{304 \times 60000}{1071068.78} = 17.029$$

$$\therefore h = (17.029)^2 = 289.98 \text{ cm of oil}$$

But
$$h = x \left[\frac{S_h}{S_o} - 1 \right]$$

where $S_h = \text{Sp. gr. of mercury} = 13.6$

$S_o = \text{Sp. gr. of oil} = 0.8$

$x = \text{Reading of manometer}$

$$\therefore 289.98 = x \left[\frac{13.6}{0.8} - 1 \right] = 16x$$

$$\therefore x = \frac{289.98}{16} = 18.12 \text{ cm.}$$

\therefore Reading of oil-mercury differential manometer = **18.12 cm.**

Problem: -13

A static pitot-tube placed in the centre of a 300 mm pipe line has one orifice pointing upstream and is perpendicular to it. The mean velocity in the pipe is 0.80 of the central velocity. Find the discharge through the pipe if the pressure difference between the two orifices is

Solution. Given :

Dia. of pipe, $d = 300 \text{ mm} = 0.30 \text{ m}$

Diff. of pressure head, $h = 60 \text{ mm of water} = .06 \text{ m of water}$

$$C_v = 0.98$$

Mean velocity, $\bar{V} = 0.80 \times \text{Central velocity}$

Central velocity is given by equation (6.14)

$$= C_v \sqrt{2gh} = 0.98 \times \sqrt{2 \times 9.81 \times .06} = 1.063 \text{ m/s}$$

$$\therefore \bar{V} = 0.80 \times 1.063 = 0.8504 \text{ m/s}$$

Discharge, $Q = \text{Area of pipe} \times \bar{V}$

$$= \frac{\pi}{4} d^2 \times \bar{V} = \frac{\pi}{4} (.30)^2 \times 0.8504 = 0.06 \text{ m}^3/\text{s. Ans.}$$

60mm of water. Take $C_v = 0.98$

FLOW THROUGH ORIFICES, NOTCHES AND WEIRS

Orifice in a small opening of any cross section such as circular, triangular rectangular etc . on the side or at the bottom of a tank through which a fluid is flowing. Orifices are used for measuring the rate of flow of fluid.

- Mouth piece is a short length of a pipe which is two or three times its diameter in length, fitted in a tank or vessel containing the fluid.
- Orifices as well as mouth piece are used for measuring the rate of flow of fluid.

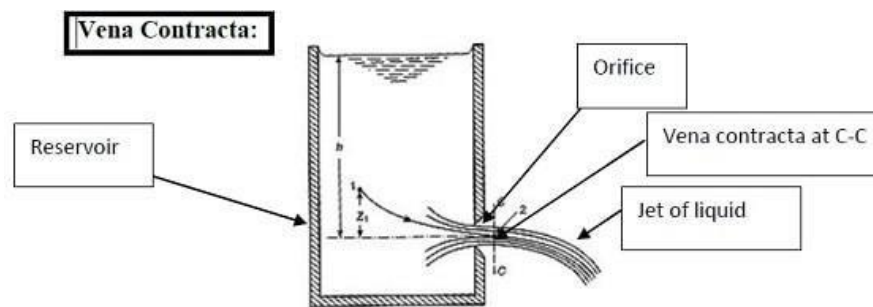

Fig. Reservoir with sharp edge orifice

JET OF WATER

The continuous stream of a liquid, that comes out or flows out of an orifice is known as the jet of water.

VENNA CONTRACTA

Consider a tank fitted with a circular orifice is one of its sides as shown in fig.

Let H be the head of the liquid above the centre of the orifice. The liquid flowing through the orifice forms a jet of liquid whose area of cross section is less than that of orifice the area of jet of fluid goes on decreasing and at a section c-c, the area is minimum. thus, section is approximately at a distance of half of diameter of the orifice at this section, the stream lines are straight and parallel to each other and perpendicular to the plane of the orifice. This section is called vena contracta beyond this section the jet diverges and is attracted in the down ward direction by the gravity.

Consider two points A & B as shown in figure, point-A is inside the tank and point-B at the Vena-contracta. Let the flow is steady and at a constant head H. Applying Bernoulli's equation at points A & B,

From Bernoulli's theorem:

$$\frac{p_1}{\rho g} + \frac{v_1^2}{2g} + Z_1 = \frac{p_2}{\rho g} + \frac{v_2^2}{2g} + Z_2$$

Placing values at points A and B

$$\frac{V_B^2}{2g} = h$$

$$V_B = \sqrt{2gh}$$

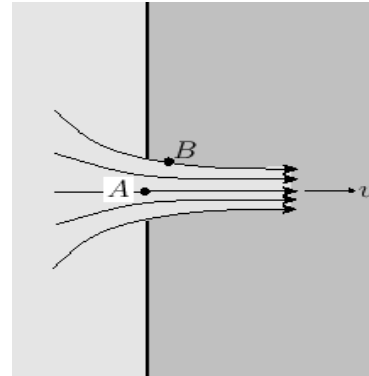

Hydraulic Co-efficients:-

The hydraulic coefficients are

- Coefficient of velocity (C_V): - It is defined as the ratio between the actual velocity of a jet of liquid at Vena contracta and the theoretical velocity of jet. It is denoted by C_V .

$$\text{Mathematically, } C_V = \frac{\text{Actual velocity of jet at vena-contracta}}{\text{Theoretical Velocity}} = \frac{V}{\sqrt{2gH}}$$

Where V = Actual velocity, $\sqrt{2gH}$ = Theoretical velocity.

The value of C_V varies from 0.95 to 0.99 for different orifices. Generally, the value of $C_V = 0.98$ is taken for sharp edged orifices.

- Coefficient of contraction (C_C): - It is defined as the ratio of the area of the jet at vena-contracta to the area of the orifice. It is denoted by C_C

Let a = area of orifice and a_c = area of jet at vena-contracta

Mathematically,

$$C_C = \frac{\text{area of jet at ven-contracta}}{\text{area of orifice}} = \frac{a_c}{a}$$

The value of C_C varies from 0.61 to 0.69.

It general the value of C_C may be taken as 0.64

- Coefficient of discharge (C_d): - It is defined as the ratio of the actual discharge from an orifice to the theoretical discharge from the orifice. It is denoted by C_d .

Let Q is actual discharge and Q_{th} is the theoretical discharge.

$$\text{Mathematically, } C_d = \frac{\text{Actual Discharge}}{\text{Theoretical Discharge}} = Q/Q_{th}$$

The value C_d varies from 0.61 to 0.65.

The value of C_d is taken as 0.62.

Relation between C_c , C_v and C_d

$$C_d = \frac{\text{Actual Discharge}}{\text{Theoretical Discharge}}$$

$$C_d = \frac{\text{Actual velocity} \times \text{Actual area}}{\text{Theoretical velocity} \times \text{Theoretical area}}$$

$$= C_c \times C_v$$

Classification

Orifices are classified on the basis of their size, shape and nature of discharge

According to size

- Small orifice (If the head of liquid above the centre of orifice is more than 5 times the depth of orifice)
- Large orifice (If head is less than 5 times the depth of orifice)

According to shape

1. Circular
2. Triangular
3. Rectangular
4. Square

According to the shape of upstream edge:

- Sharp edged orifice
- Bell mouthed orifice

According to nature of discharge:

- Free discharge orifices
- Drowned or submerged orifices
 - Partially submerged orifices
 - Fully submerged orifices

Q.1):- The head of water over an orifice of diameter 40mm is 10m. Find the actual discharge and actual velocity of the jet at vena-contracta. Take $C_d=0.6$ and $C_v=0.98$.

ANS:- Given: $H=10\text{m}$, Dia. Of orifice, $d=40\text{mm}=0.04\text{m}$, Area, $a = \frac{\pi \times (0.04)^2}{4} = 0.001256\text{m}^2$, $C_d=0.6$, $C_v=0.98$

$$C_d = \frac{\text{Actual discharge}}{\text{Theoretical discharge}} = 0.6$$

But Theoretical discharge = $V_{th} \times \text{Area of orifice}$

V_{th} = theoretical velocity, where $V_{th} = \sqrt{2gH} = \sqrt{2 \times 9.8 \times 10} = 14\text{m/sec}$

Theoretical discharge = $14 \times 0.001256 = 0.01758\text{m}^3/\text{sec}$

Actual discharge = $0.6 \times \text{theoretical discharge}$

$$= 0.6 \times 0.01758 = 0.010548\text{m}^3/\text{sec}$$

$$C_v = \frac{\text{Actual velocity}}{\text{Theoretical velocity}} = C_v = 0.98$$

$$\Rightarrow \text{Actual velocity} = 0.98 \times 14 = 13.72\text{ m/sec}$$

2) The head of water over an orifice of diameter 50 mm is 12m. Find actual discharge and actual velocity of jet at Vena-contracta. Take $C_d=0.6$ and $C_v=0.98$.

3) The head of water over the centre of an orifice of diameter 30 mm is 1.5 m. The actual discharge through the orifice is 2.35 litres/sec. Find the co-efficient of discharge.

FLOW THROUGH NOTCHES AND WEIRS

A Notch is a device used for measuring the rate of flow of a liquid through a small channel or a tank. It may be defined as an opening in the side of a tank or a small channel in such a way that the liquid surface in the tank or channel is below the top edge of the opening.

A Weir is a concrete or masonry structure, placed in an open channel over which the flow occurs. It generally in the form of vertical wall, with a sharp edge at the top, running all the way across the open channel.

The notch is of small size while the weir is of a bigger size. The notch is generally made of metallic plate while weir is made of concrete or masonry structure.

Notch- is a device used for measuring the rate of flow or discharge of a liquid through small channel or tank.

Weir- is a concrete or masonry structure, placed in an open channel over which the flow occurs.

It is form of vertical wall, with the sharp edge at the top, running all the way across the open channel.

- NAPPE OR VEIN- The sheet of water flowing through a notch or over a weir is called nappe or vein.
- CREST OR SILL- The bottom edge of notch or a top of a weir over which the water flows, is known the sill or crest.

Classification of Notches and Weirs

Notches are classified as:

1. According to the shape of opening

- a) Rectangular notch
- b) Triangular notch
- c) Trapezoidal notch
- d) Stepped notch

2. According to the effect of the sides on the nappe

- a) Notch with end contraction
- b) Notch without end contraction or suppressed notch

Weir are classified according to the shape of the opening, the shape of the crest, the effect of the sides on the nappe and the nature of discharge

- a) According to the shape of the opening:
 1. Rectangular weir
 2. Triangular weir
 3. Trapezoidal weir
- b) According to the shape of the crest
 1. Sharp-crested weir
 2. Broad-crested weir
 3. Narrow-crested weir
 4. Ogee-shaped weir
- c) according to the effect of the sides on the emerging nappe
 1. weir with end contraction
 2. weir without end contraction

Discharge over rectangular notch or weir:

The expression for discharge over a rectangular notch or weir is the same.

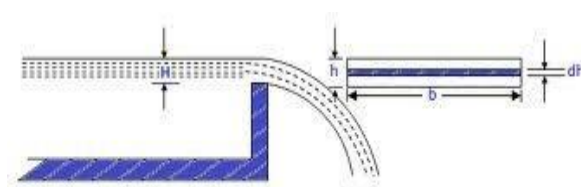

Fig : Rectangular Notch

Consider a rectangular notch or weir provided in a channel carrying water as shown in figure----

Let H - Head of water over the crest

L -Length of the notch or weir

For finding the discharge of water flowing over the weir or notch, consider an elementary horizontal strip of water of thickness dh and length L at a depth h from the free surface of water as shown in figure.

The area of strip = $L \times dh$

And theoretical velocity of water flowing through strip = $\sqrt{2gh}$

The discharge dQ , through strip is

$dQ = C_d \times \text{area of strip} \times \text{Theoretical velocity}$

$$C_d \times L \times dh \times \sqrt{2gh} \quad \dots (i)$$

Where C_d = co efficient of discharge.

The total discharge, Q , for the whole notch or weir is determined by integrating equation (i) between the limit 0 and H .

$$\begin{aligned} Q &= \int_0^H C_d \cdot L \cdot \sqrt{2gh} \cdot dh \\ &= C_d \times L \cdot \sqrt{2g} \int_0^H h^{1/2} dh \\ &= \frac{2}{3} C_d \times L \times \sqrt{2g} (H)^{3/2} \end{aligned}$$

Discharge over a triangular notch or weir

The expression for the discharge over a triangular notch or weir is the same. It is derived as:

Let H = head of water above the V-notch

θ = angle of notch

Consider a horizontal strip of water of thickness dh at a depth of h from the free surface of water as shown in fig.

Fig. 9.3 shown a triangular notch.

Let H = head of water over the apex
 θ = Angle of the notch

Width of the notch at any depth h

$$= 2(H-h) \tan \frac{\theta}{2}$$

Consider an elemental horizontal strip of the opening at depth h and having a height

dh . The theoretical velocity of flow through the strip $= \sqrt{2gh}$

\therefore Theoretical discharge through the strip

$$= 2(H-h) \tan \frac{\theta}{2} dh \sqrt{2gh}$$

$$\text{Total discharge} = Q = \int_0^H 2\sqrt{2g} \tan \frac{\theta}{2} (H-h) h^{1/2} dh$$

$$= 2\sqrt{2g} \tan \frac{\theta}{2} \left[H \frac{2}{3} H^{3/2} - \frac{2}{5} H^{5/2} \right] = \frac{8}{15} \sqrt{2g} \tan \frac{\theta}{2} H^{5/2}$$

$$\text{Actual discharge} = q = \frac{8}{15} C_d \sqrt{2g} \tan \frac{\theta}{2} H^{5/2}$$

where C_d = Coefficient of discharge

The vertex angle for a triangular notch may be from 25° to 90° . A vertex angle of 90° is commonly adopted. The coefficient of discharge is found to depend on the vertex angle. At lower heads and lower vertex angles the values of C_d are found to be higher. This may be due to a lesser degree of contraction of the nappe.

$$\text{For a } 90^\circ \text{ notch } \tan \frac{\theta}{2} = 1$$

$$\text{and the discharge} = q = \frac{8}{15} C_d \sqrt{2g} H^{5/2}$$

Taking

$$C_d = 0.6, \text{ we have}$$

$$\frac{8}{15} C_d \sqrt{2g} = \frac{8}{15} \times 0.6 \sqrt{2 \times 9.81} = 1.47$$

and accordingly

$$q = 1.417 H^{5/2}$$

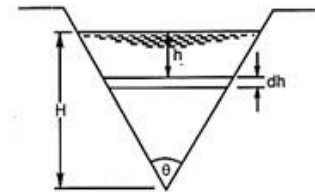

Fig. 9.3.

Q: - Find the discharge of water flowing over a rectangular notch of 2m length when the constant head over the notch is 300mm. Take $C_d = 0.60$

Ans: -

Given: Length of the notch, $L=2.0\text{m}$, Head over notch, $H = 300\text{mm} = 0.30\text{m}$, $C_d=0.60$

$$\begin{aligned} \text{Discharge, } Q &= \frac{2}{3} C_d \times L \times \sqrt{2g} (H)^{3/2} \\ &= \frac{2}{3} \times 0.6 \times 2.0 \times \sqrt{2 \times 9.81} (0.30)^{1.5} \text{m}^3/\text{sec} \\ &= \end{aligned}$$

Q: -Find the discharge over a triangular notch of angle 60° when the head over the V-notch is 0.3 m. Assume $C_d = 0.6$

Ans: - Given:

Angle of V-notch, $\phi = 60^\circ$, Head over notch, $H = 0.3\text{m}$, $C_d = 0.6$

Discharge, Q over a V-notch is given by equation

$$\begin{aligned} Q &= \frac{8}{15} \times 0.6 \tan \phi/2 \times \sqrt{2g} \times H^{5/2} \\ &= \frac{8}{15} \times 0.6 \tan 60/2 \times \sqrt{2 \times 9.81} \times (0.3)^{5/2} \\ &= 0.8182 \times 0.0493 = 0.040 \text{ m}^3/\text{sec} \end{aligned}$$

FLOW THROUGH PIPES

Pipe:

A pipe is a closed conduit, generally of circular cross-section used to carry water or any other fluid.

When the pipe is running full, the flow is under pressure but if the pipe is not running full the flow is not under pressure (culverts, sewer pipes).

Loss of fluid friction:

The frictional resistance of a pipe depends upon the roughness of the inside surface of the pipe more the roughness more is the resistance. This friction is known as fluid friction and the resistance is known as frictional resistance

According Froude

The frictional resistance varies with the square of the velocity.

The friction resistance varies with the natural of the surface. Among various laws, the Darcy-weisbach formula & Chezy's formula.

Loss of energy in pipes:

When a fluid is flowing through a pipe, the fluid experiences some resistance due to which some energy is lost.

Energy losses

Major losses due to

to friction

it is calculated by

a-Darcy-weisbach formula
of pipe

b-Chezy's formula

Minor losses due

1-sudden expansion of pipe

2-sudden contraction

3-bend in pipe

4-pipe fittings etc

5-an obstruction in pipe.

Darcy- weisbach formula:

The loss of head in pipes due to friction calculated from darcy-weisbach equation.

$$h_f = 4. f.L. \frac{V^2}{d \times 2g}$$

where h_f = loss of head due to friction, f = Co-efficient of friction which is a function of Reynold number

$$= 16/R_e \text{ for } R_e < 2000 \text{ (viscous flow)}$$

$$= 0.079/R_e^{1/4} \text{ for } R_e \text{ varying from } 4000 \text{ to } 10^6$$

Where L = length of pipe,

V = mean velocity of flow,

d = diameter of pipe

b) Chezy 's formula for loss of head due to friction in pipes

As we know the expression for loss of head due to friction in pipes is

$$h_f = \frac{fL}{\rho g} \times \frac{P}{A} \times L \times V^2 \dots\dots(1)$$

Where h_f = loss of head due to friction, P = wetted perimeter of pipe, A = area of cross section of pipe,

L = length of pipe, and V = mean velocity of flow .

$$\text{Hydraulic mean depth, } m = \frac{A}{P} = \frac{\frac{\pi d^2}{4}}{\pi d} = \frac{d}{4}$$

Substituting $\frac{A}{P} = m$ or $\frac{P}{A} = \frac{1}{m}$ in the equation (1), we get,

$$H_f = \frac{fL}{\rho g} \times \frac{L \times V^2}{m},$$

$$\text{or } V^2 = h_f \times \frac{\rho g}{fL} \times m \times \frac{1}{L} = \frac{\rho g}{fL} \times m \times \frac{h_f}{L}$$

$$V = \sqrt{\frac{\rho g}{fL}} \times m \times \frac{h_f}{L} = \sqrt{\rho g / fL} \sqrt{m h_f / L}$$

Let $\sqrt{\rho g / fL} = C$, where C is a constant known as Chezy' s constant and

$h_f / L = i$, where i is loss of head per unit length of pipe.

Substituting the values of $\sqrt{\rho g / fL}$ and $\sqrt{h_f / L}$

$$V = C \sqrt{mi}$$

This equation is known as Chezy's formula.

Q: - Find the head lost due to friction in a pipe of diameter 300mm and length 50m, through which is flowing at a velocity of 3m/sec using (i) Darcy formula, (ii) Chezy's formula for which $C = 60$. Take ν for water = 0.01 stoke.

Ans: - Given:

Dia. Of pipe, $d=300\text{mm}=0.30\text{m}$, Length of pipe, $L=50\text{M}$, Velocity of flow, $V=3\text{m/sec}$, Chezy's constant, $C=60$, kinematic viscosity, $\nu = 0.01 \text{ stoke} = 0.01 \text{ cm}^2/\text{sec} = 0.01 \times 10^{-4} \text{ m}^2/\text{sec}$

(i) Darcy formula:

$$h_f = 4.f.L.V^2/d \times 2g$$

where f = co-efficient of friction is a function of Reynold number, R_e

$$\text{But } R_e = V \times d / \nu = 3.0 \times 0.30 / 0.01 \times 10^{-4} = 9 \times 10^5$$

$$\text{Value of } f = 0.079 / R_e^{1/4} = 0.079 / (9 \times 10^5)^{1/4} = 0.00256$$

$$\text{Head lost, } h_f = 4 \times 0.00256 \times 50 \times 3^2 / 0.3 \times 2.0 \times 9.81 = 0.7828\text{m.}$$

(ii) Chezy's formula:

$$V = C \sqrt{mi}, \text{ where } C=60, m=d/4=0.30/4=0.075\text{m}$$

$$\Rightarrow 3 = 60 \sqrt{0.075 \times i} \quad \text{or, } i = (3/60)^2 \times 1/0.075 = 0.0333$$

$$\text{But } i = h_f/L = h_f/50 \Rightarrow h_f/50 = 0.0333 \Rightarrow h_f = 50 \times 0.0333 = 1.665\text{m.}$$

Q:- A crude oil of kinematic viscosity 0.4 stoke is flowing through a pipe of diameter 300mm at the rate of 300 litres per sec. Find the head lost due to friction for a length of 50m of the pipe.

Ans:- Given:-

$$\text{Kinematic viscosity, } \nu = 0.4 \text{ stoke} = 0.4 \text{ cm}^2/\text{sec} = 0.4 \times 10^{-4} \text{ m}^2/\text{sec}$$

$$\text{Dia. Of pipe, } d = 300\text{mm} = 0.30\text{m}$$

$$\text{Discharge, } Q = 300\text{litres/sec} = 0.3 \text{ m}^3/\text{sec}$$

$$\text{Discharge, } Q = 300\text{litres/sec} = 0.3 \text{ m}^3/\text{sec}$$

Length of pipe, $L= 50\text{m}$

Velocity of flow, $V=Q/\text{Area}=0.3/\left[\frac{\pi}{4}(0.3)^2\right]= 4.24\text{m/sec}$

Reynold number, $R_e=V \times d/v=4.24 \times 0.30/0.4 \times 10^{-4}=3.18 \times 10^4$

As R_e lies between 4000 and 100,000, the value of f is given by

$$f = 0.079/(R_e)^{1/4} = 0.079/(3.18 \times 10^4)^{1/4} = 0.00591$$

Head lost due to friction,

$$h_f = 4 \cdot f \cdot L \cdot \frac{V^2}{d \times 2g} = 4 \times 0.00591 \times 50 \times \frac{4.24^2}{0.3 \times 2 \times 9.81} = 3.61\text{m}.$$

Hydraulic gradient line:

It is defined as the line which gives the sum of pressure head P/W & datum head (Z) if a flowing fluid in a pipe with respect to the reference line or it is the line which is obtained by joining of the top of all vertical ordinates showing pressure head (P/W) of a flowing fluid in a pipe from the centre of the pipe. It is briefly written as H.G.L .

Total energy line:

It is defined as the line which gives the sum of pressure head, datum head & kinetic head of a flowing fluid in a pipe with respect to some reference line or it is the line which is obtained by joining the tops of all vertical ordinates showing the sum of pressure head & kinetic head from the centre of the pipe. It is also written as T.E.L

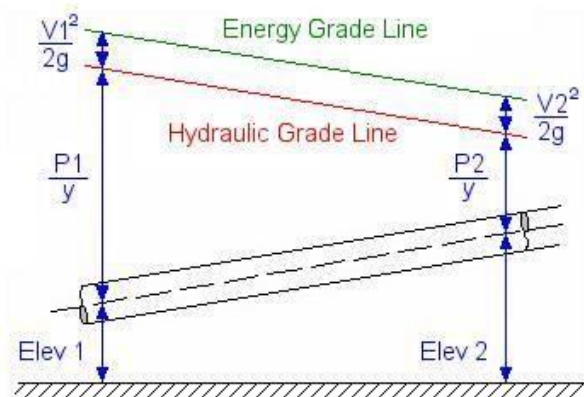

- Reference: - i) A textbook of Fluid mechanics
and Hydraulic machines by R.K. Bansal**
- ii) A textbook of Hydraulics, Fluid mechanics
and Hydraulic machines by R.S. Khurmi**
- iii) A textbook of Fluid mechanics
and Hydraulic machines by R.K. Rajput**

Reference link:-

- i) <https://youtu.be/OwC5Dmtau98>
- ii) <https://youtu.be/VvDJyhYSJv8>
- iii) https://youtu.be/ikt-MxC3_1o
- iv) <https://youtu.be/bRYVwDsXKfE>
- v) <https://youtu.be/i49Nv-EVxdM>
- vi) <https://youtu.be/dirxdpSZZBM>
- vii) <https://youtu.be/DW4rItB20h4>
- viii) <https://youtu.be/vhnXASB6PSw>
- ix) <https://youtu.be/PMI7fVwzNuM>
- x) <https://youtu.be/moI4DQnirAw>
- xi) <https://youtu.be/fHepVMqITVo>